

JVC



DIGITAL VIDEO CAMERA

GR-DVJ70



Mini **DV** PAL

INSTRUCTIONS



CONTENTS

ABOUT DVC	5
QUICK OPERATION GUIDE	6
ACCESSORIES	7
GETTING STARTED	8
Charging The Battery	8
Installing The Battery	9
Indoor Use	10
Using The CAM Stand	10
Clock (Lithium) Battery CR2025	
Insertion/Removal	11
Date/Time Settings	12
Loading/Unloading	
A Cassette	13
Hand Strap Attachment	14
Diopter Adjustment	14
Remote Control	15
RECORDING	16
Full Auto/Manual Operation	16
Menus	17
Basic Recording	21
Advanced Features	23
PLAYBACK	42
Basic Connections	42
Basic Playback	45
Playback Menu	46
Advanced Features	48
EDITING	50
Docking Station	50
Dubbing	50
Brand Setting	51
Random Assemble Editing	52
For More Accurate Editing	55
Audio Dubbing	57
Insert Editing	58
TROUBLESHOOTING	59
AFTER USE	62
CONTROLS, INDICATIONS AND CONNECTORS	63
Main Unit	63
Viewfinder Indications	64
Docking Station	65
CAUTIONS	66
SPECIFICATIONS	68
GLOSSARY OF TERMS	70
INDEX	71

Dear Customer,

Thank you for purchasing this Digital Video Camera. Before use, please read the safety information and precautions contained in the following pages to ensure safe use of this product.

Using This Instruction Manual

- All major sections and subsections are listed in the cover.
- Notes appear after most subsections. Be sure to read these as well.
- Basic and advanced features/operation are separated for easier reference.

It is recommended that you . . .

- refer to "Controls, Indications and Connectors" (☞ pgs. 63 – 65) and familiarize yourself with button locations, etc. before use.
- read thoroughly the Safety Precautions and Safety Instructions that follow. They contain extremely important information regarding the safe use of your new camcorder.

You are recommended to carefully read the cautions on pages 66 and 67 before use.

SAFETY PRECAUTIONS

IMPORTANT**Connection to the mains supply in the United Kingdom.****DO NOT cut off the mains plug from this equipment.**

If the plug fitted is not suitable for the power points in your home or the cable is too short to reach a power point, then obtain an appropriate safety approved extension lead or consult your dealer.

BE SURE to replace the fuse only with an identical approved type, as originally fitted, and to replace the fuse cover.

If nonetheless the mains plug is cut off ensure to remove the fuse and dispose of the plug immediately, to avoid a possible shock hazard by inadvertent connection to the mains supply. If this product is not supplied fitted with a mains plug then follow the instructions given below: **DO NOT** make any connection to the Larger Terminal coded E or Green.

The wires in the mains lead are coloured in accordance with the following code:

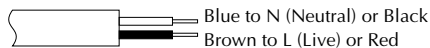

If these colours do not correspond with the terminal identifications of your plug, connect as follows:

Blue wire to terminal coded N (Neutral) or coloured black.

Brown wire to terminal coded L (Live) or coloured Red.

If in doubt — consult a competent electrician.

**WARNING:
TO PREVENT FIRE OR SHOCK
HAZARD, DO NOT EXPOSE THIS
UNIT TO RAIN OR MOISTURE.****Warning on lithium cell battery**

The battery used in this device may present a fire or chemical burn hazard if mistreated. Do not recharge, disassemble, heat above 100°C or incinerate.

Replace battery with Panasonic (Matsushita Electric), Sanyo or Maxell CR2025; use of another battery may present a risk of fire or explosion.

- Dispose of used battery promptly.
- Keep away from children.
- Do not disassemble and do not dispose of in fire.

WARNING: AC Power Adapter/Charger is NOT FOR USE WITH TOYS.

CAUTIONS:

- To prevent shock, do not open the cabinet. No user serviceable parts inside. Refer servicing to qualified personnel.
- When you are not using the AC Power Adapter/Battery charger for a long period of time, it is recommended that you disconnect the power cord from AC outlet.

CAUTION

(applies to the Docking Station):

TO REDUCE THE RISK OF FIRE, DO NOT REMOVE COVER (OR BACK). NO USER-SERVICEABLE PARTS INSIDE. REFER SERVICING TO QUALIFIED SERVICE PERSONNEL.

NOTES:

- *The rating plate (serial number plate) and safety caution are on the bottom and/or the back of the main unit.*
- *The rating plate (serial number plate) of the AC Power Adapter/Charger is on its bottom.*

This camcorder is designed to be used with PAL-type color television signals. It cannot be used for playback with a television of a different standard. However, live recording and viewfinder playback are possible anywhere. Use the BN-V712U/BN-V714U battery pack and, to recharge it, the provided multi-voltage AC Power Adapter/Charger. (An appropriate conversion adapter may be necessary to accommodate different designs of AC outlets in different countries.)

This unit is produced to comply with Standard IEC Publ. 65.

Mini **DV** PAL

- This camcorder is designed exclusively for the Mini **DV** digital video cassette. Only cassettes marked Mini **DV** can be used with this unit.

SOME DO'S AND DON'TS ON THE SAFE USE OF EQUIPMENT

This equipment has been designed and manufactured to meet international safety standards but, like any electrical equipment, care must be taken if you are to obtain the best results and safety is to be assured.

- DO** read the operating instructions before you attempt to use the equipment.
- DO** ensure that all electrical connections (including the mains plug, extension leads and interconnections between pieces of equipment) are properly made and in accordance with the manufacturer's instructions. Switch off and withdraw the mains plug when making or changing connections.
- DO** consult your dealer if you are ever in doubt about the installation, operation or safety of your equipment.
- DO** be careful with glass panels or doors on equipment.
- DON'T** continue to operate the equipment if you are in any doubt about it working normally, or if it is damaged in any way — switch off, withdraw the mains plug and consult your dealer.
- DON'T** remove any fixed cover as this may expose dangerous voltages.
- DON'T** leave equipment switched on when it is unattended unless it is specifically stated that it is designed for unattended operation or has a standby mode. Switch off using the switch on the equipment and make sure that your family knows how to do this. Special arrangements may need to be made for infirm or handicapped people.
- DON'T** use equipment such as personal stereos or radios so that you are distracted from the requirements of road safety. It is illegal to watch television whilst driving.
- DON'T** listen to headphones at high volume, as such use can permanently damage your hearing.
- DON'T** obstruct the ventilation of the equipment, for example with curtains or soft furnishings. Overheating will cause damage and shorten the life of the equipment.
- DON'T** use makeshift stands and NEVER fix legs with wood screws — to ensure complete safety always fit the manufacturer's approved stand or legs with the fixings provided according to the instructions.
- DON'T** allow electrical equipment to be exposed to rain or moisture.
- ABOVE ALL**
 - NEVER let anyone especially children push anything into holes, slots or any other opening in the case — this could result in a fatal electrical shock;
 - NEVER guess or take chances with electrical equipment of any kind — it is better to be safe than sorry!

SAFETY PRECAUTIONS

CAUTION:

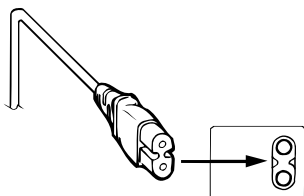

To avoid electric shock or damage to the unit, first firmly insert the small end of the power cord into the AC Power Adapter/Charger until it is no longer wobbly, and then plug the larger end of the power cord into an AC outlet.

Do not point the lens or the viewfinder directly into the sun. This can cause eye injuries, as well as lead to the malfunctioning of internal circuitry. There is also a risk of fire or electric shock.

CAUTION! The following notes concern possible physical damage to the camcorder and to the user.

When carrying, be sure to always attach and use the provided hand strap. Hold the camcorder firmly in your hand, with the strap securely around your wrist. Carrying or holding the camcorder by the viewfinder can result in dropping the unit, or in a malfunction.

Take care not to get your finger caught in the cassette cover. Do not let children operate the camcorder, as they are particularly susceptible to this type of injury.

Do not use a tripod on unsteady or unlevel surfaces. It could tip over, causing serious damage to the camcorder.

CAUTION! Attaching the camcorder to the Docking Station, connecting cables (AUDIO/VIDEO, S-VIDEO, Editing, DC) and leaving the unit on top of the TV is not recommended, as tripping on the cables will cause the camcorder to fall, resulting in damage.

About Batteries

DANGER! Do not attempt to take the batteries apart, or expose them to flame or excessive heat, as there is a risk of fire or explosion.

WARNING! Do not allow the battery terminals, or the battery itself, to come in contact with metals, as this can result in a short circuit and possibly start a fire.

- When transporting, make sure the provided battery cap is attached to the battery. If you misplace the battery cap, carry the battery in a plastic bag.

Before recording an important scene . . .

- make sure you only use cassettes with the Mini DV mark.
- remember that the GR-DVJ70 is not compatible with other digital video formats.
- remember that the GR-DVJ70 is intended for private consumer use only. Any commercial use without proper permission is prohibited. (Even if you record an event such as a show, performance or exhibition for personal enjoyment, it is strongly recommended that you obtain permission beforehand.)

The Benefits Of Lithium-Ion Batteries

Lithium-ion batteries are small yet have a large power capacity. However, if exposed to extreme cold (below 10°C), the effective operational time decreases significantly. Exposure to temperatures below 0°C will render the battery inoperative. If you are planning to shoot in an environment at these temperatures, carry the battery in a pocket to keep it warm, then attach it just prior to recording. The optional power grip CU-V778U is also recommended. It holds two batteries, and keeps them sufficiently warm even at an outside temperature of 0°C.

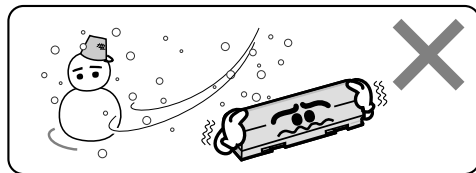

Lithium-ion is vulnerable in colder temperatures.

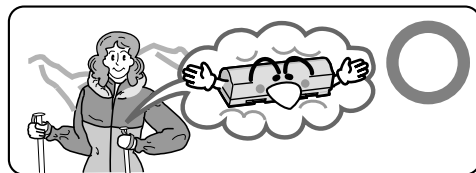

Keep the battery in a pocket when not in use, or use the optional CU-V778U power grip.

The digital video camera converts incoming audio and video signals into digital form for recording.

A video signal is composed of a luminance signal (Y) and colour signals (R-Y and B-Y). These signals are identified and recorded digitally (Digital Component Recording). The A/D (Analog to Digital) converter samples the Y signal at 13.5 MHz, and R-Y and B-Y at 6.75 MHz, and changes them to an 8-bit quantum signal.

Sound sampled at 48 kHz is changed to a 16-bit quantum signal, and sound sampled at 32 kHz is converted to a 12-bit signal.

NOTE:

The data recorded on a tape is digital, but the output of the GR-DVJ70 is analogue.

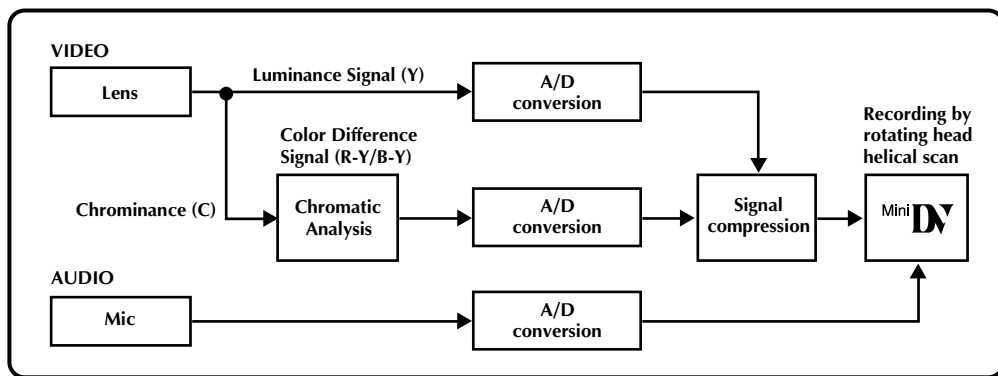

The GR-DVJ70 separates the data into blocks, writing one block of each data type on each track of the tape.

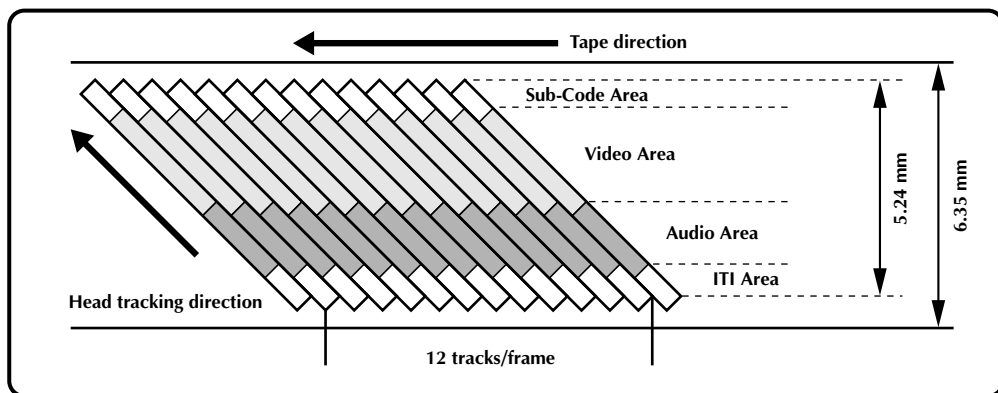

1 Sub-Code Area

The Time Code and Date/Time data are written here, separate from the video data. This enables you to display the date and time during playback, even if they weren't displayed while recording.

2 Video Area

The digital video signal is recorded here.

3 Audio Area

The digital audio signal is recorded here.

4 ITI (Insert and Tracking Information) Area

Insert editing and post-recording editing tracking signals are recorded here.

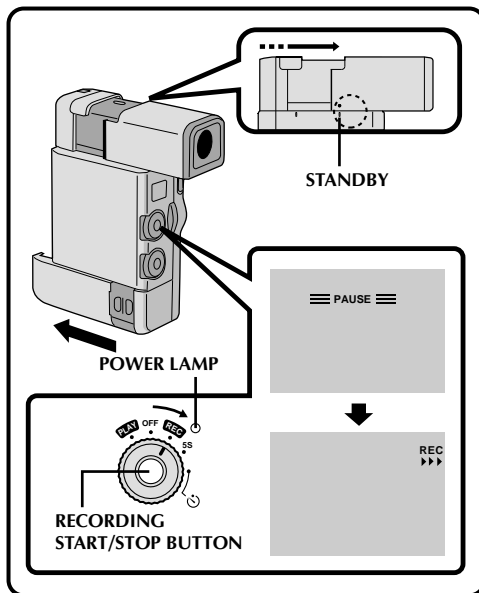
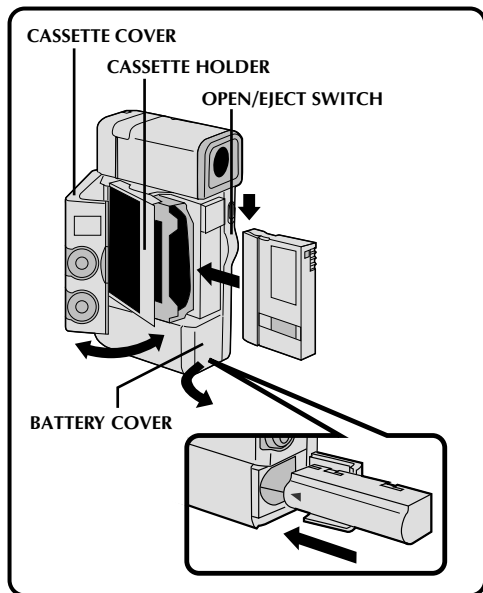

SUPPLYING POWER

Install A Fully Charged Battery

- 1 Open the battery cover in the direction of the arrow.
- 2 Remove the battery's protective cap and insert the battery + - first.
- 3 Close the battery cover.

LOADING A CASSETTE

- 1 Turn on the power, then slide the OPEN/EJECT switch in the direction of the arrow. The cassette cover releases. Open the cover in the direction of the arrow until it locks. The holder opens automatically.
- 2 Insert a tape.
- 3 Close the holder and it recedes automatically.
- 4 Close the cassette cover.

RECORDING

- 1 Pull out the viewfinder and align the mark with "STANDBY". The lens cover opens automatically.
- 2 Set the Power Dial to "REC", then press **RECORDING START/STOP**. A "beep" signals the start of recording.
- 3 To pause during recording, press **RECORDING START/STOP**. Two beeps indicate the RECORD/STANDBY mode.
- 4 When you're finished, push the viewfinder in, aligning its mark with "CAMERA OFF".

PLAYBACK

- 1 Pull out the viewfinder. The lens cover opens automatically.
- 2 Set the Power Dial to "PLAY".
- 3 Slide open the camcorder's Operation Panel cover.
- 4 Press **REW** to rewind the tape to the beginning.
- 5 Press **PLAY** and watch what you've recorded in the viewfinder.
- 6 When you're finished, press **STOP**.

PROVIDED ACCESSORIES

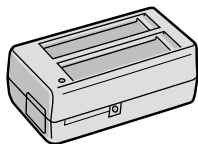

AC Power Adapter/
Charger AA-V70EK

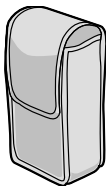

Soft camera case

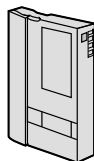

MiniDV Cassette
Tape 30 min
M-DV30ME



Lithium battery
CR2025
(for clock operation)

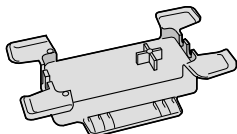

CAM Stand

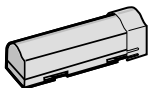

Battery pack
BN-V714U

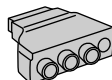

Cable adapter

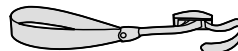

Hand strap

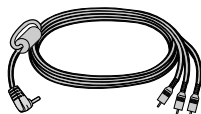

AUDIO and VIDEO cable
(ø3.5 DV TV or VCR)

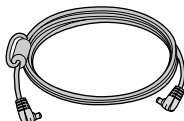

DC cord

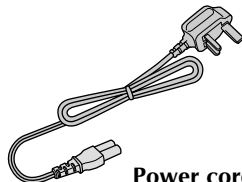

Power cord

OPTIONALLY AVAILABLE ACCESSORY KIT

For the operations on pg. 42 – 44, 46 – 58 purchase the accessory kit CU-V70KIT E (available optionally).

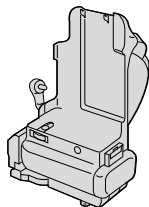

Power Grip
CU-V778U



Remote control unit
RM-V708U or
RM-V710U

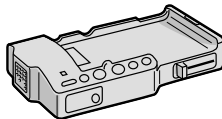

Docking Station



Lithium battery
CR2025
(for remote
control unit)

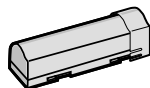

Battery pack
BN-V714U

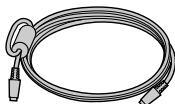

S-VIDEO cable



Editing cable

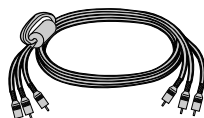

AUDIO and VIDEO cable
(Phono Docking Station
TV or VCR)

Charging The Battery

You can charge one battery pack at a time, or two consecutively.

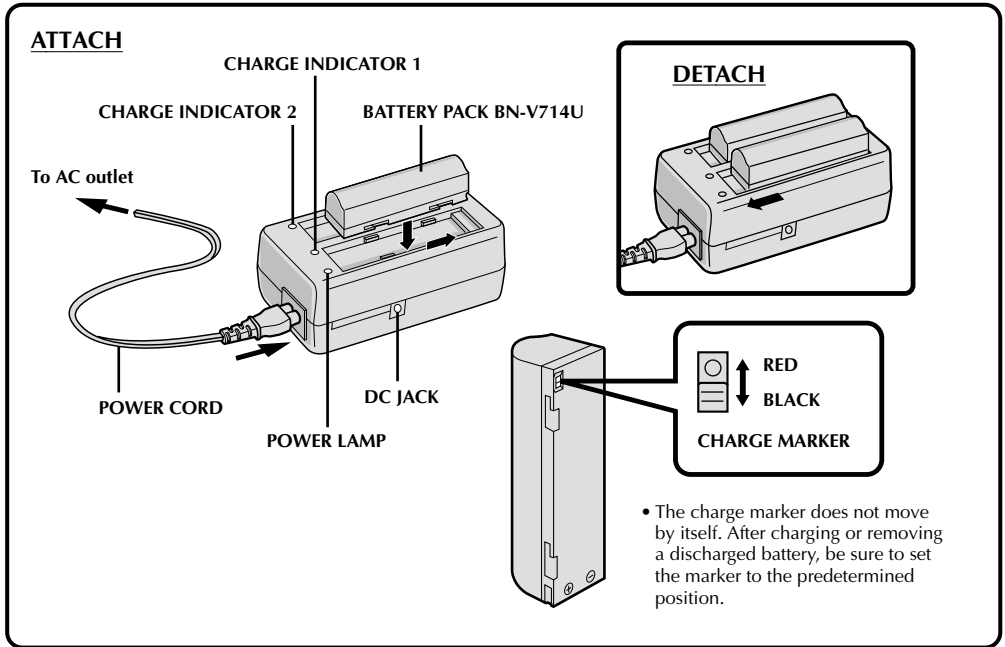

1 SUPPLY POWER TO CHARGER

Connect the power cord between the AC Power Adapter/Charger and an AC outlet. The power indicator comes on.

2 ATTACH BATTERY/BATTERIES

Remove the battery pack's protective cap and make sure the + - marks are facing down and aligned with the corresponding marks on the AC Power Adapter/Charger.

- The Charge Indicator begins blinking to indicate charging has started.
- To charge two batteries consecutively, attach one right after the other. If you attach a second battery while the first one is being charged, the time required for charging will increase.

Charge Marker

The charge marker makes it easy for you to differentiate between charged and discharged batteries. Choose RED or BLACK to mean charged or discharged, and you'll always know the status of your batteries.

3 CONFIRM STATUS

When the charge indicator stops blinking but stays on, charging is finished. (If two batteries are attached, this means that they've both been charged.)

CHARGING TIME

BATT. PACK	ONE	TWO
BN-V712U	approx. 140 min.	approx. 210 min.
BN-V714U	approx. 170 min.	approx. 240 min.

4 DETACH BATTERY/BATTERIES

Slide the battery or batteries in the direction of the arrow and lift off.

- Remember to unplug the power cord from the AC Power Adapter/Charger.

NOTES:

- If you connect the camcorder's DC cord to the adapter during battery charging, power is supplied to the camcorder and charging stops.
- When using the AC Power Adapter/Charger, be sure to use the supplied power cord only.
- When charging the Battery Pack for the first time or after a long storage period, the Charge Indicator may not light. In this case, remove the Battery Pack from the AC Power Adapter/Charger, then try charging again.
- Since the AC Power Adapter/Charger processes electricity internally, it becomes warm during use. Be sure to use it only in well-ventilated areas.
- Be sure to securely connect the power cord to the AC Power Adapter/Charger.
- Before connecting to an AC outlet, connect the power cord to the AC Power Adapter/Charger. If you plug into an AC outlet first and the power cord's terminal comes in contact with a metal surface or object, there is the possibility of a short circuit or fire.

** Charging Environment

Perform charging where the temperature is between 10° and 30°C. (20°–25°C is the ideal temperature range for charging.) If the environment is too cold, charging may be incomplete.

Recording Time

BATT. PACK	RECORDING TIME
BN-V712U	approx. 30 min.
BN-V714U	approx. 50 min.

Recording time under the following conditions:

- The temperature is approximately 20°C
- However, . . .
- If the temperature is below 10°C, or
 - If Zoom or RECORD/STANDBY are engaged repeatedly, continuous shooting capability is reduced significantly. Before extended use, it is recommended that you prepare enough battery packs to cover 3 times the planned shooting time.

Installing The Battery Pack

The battery pack does not charge while in the camcorder. Before installation, make sure the battery pack has been charged fully.

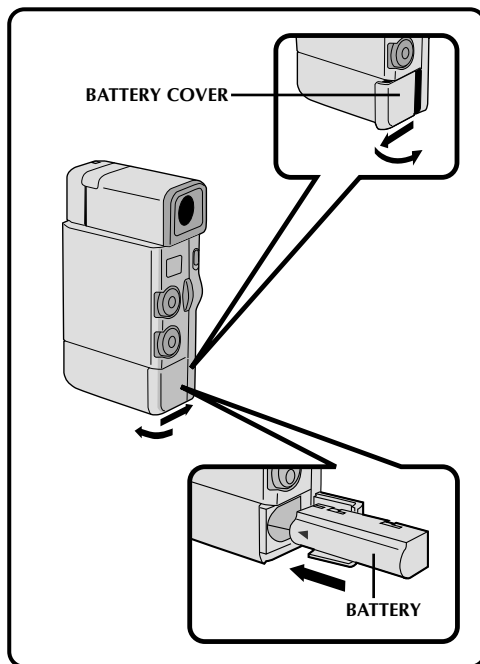

1

OPEN BATTERY COVER

Move the cover in the direction of the arrow.

2

INSERT BATTERY

Remove its protective cap and insert the + – end of the battery first.

3

CLOSE BATTERY COVER

NOTE:

To remove a discharged battery pack, simply open the cover and slide the battery pack out.

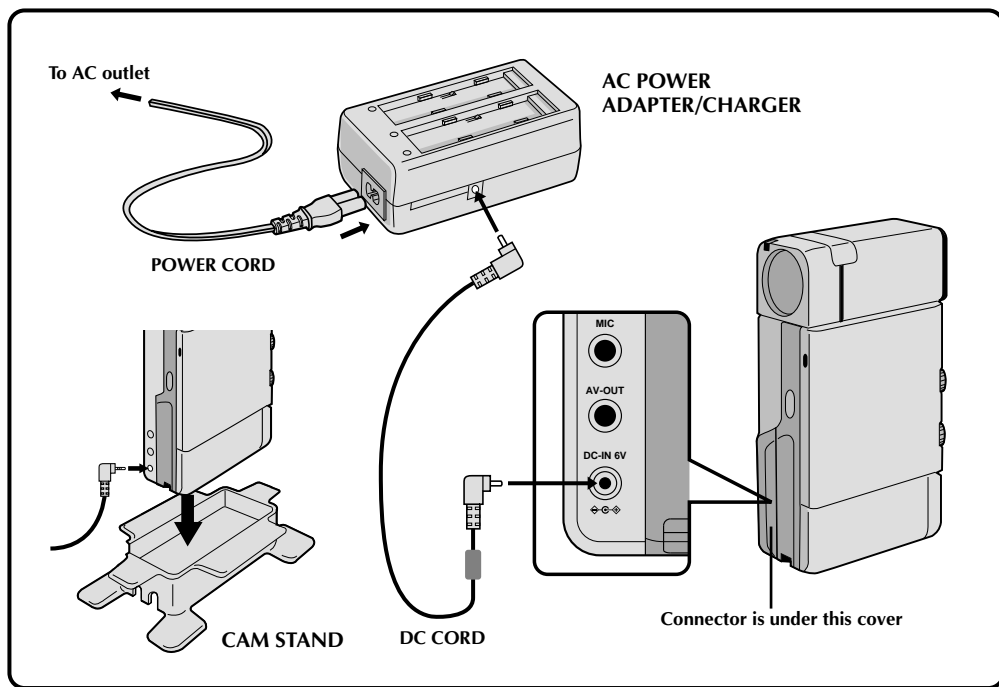

Indoor Use

When using the camcorder indoors, you can use the AC Adapter instead of a battery.

1 SUPPLY POWER TO ADAPTER

Connect the power cord between the AC Adapter and an AC outlet.

2 SUPPLY POWER TO CAMCORDER

Connect the AC Adapter to the camcorder.

Using The CAM Stand

During Recording

If you record while leaving the camcorder on a desk or table, it may tip or be accidentally knocked over. Attach it to the CAM Stand before this type of use.

1 SUPPLY POWER

Plug the DC Power Cord into the camcorder.

2 ATTACH TO CAM STAND

Attach as shown in the illustration, paying particular attention to the DC Power Cord.

Clock (Lithium) Battery CR2025 Insertion/Removal

This battery is necessary to operate the clock and to perform date/time settings.

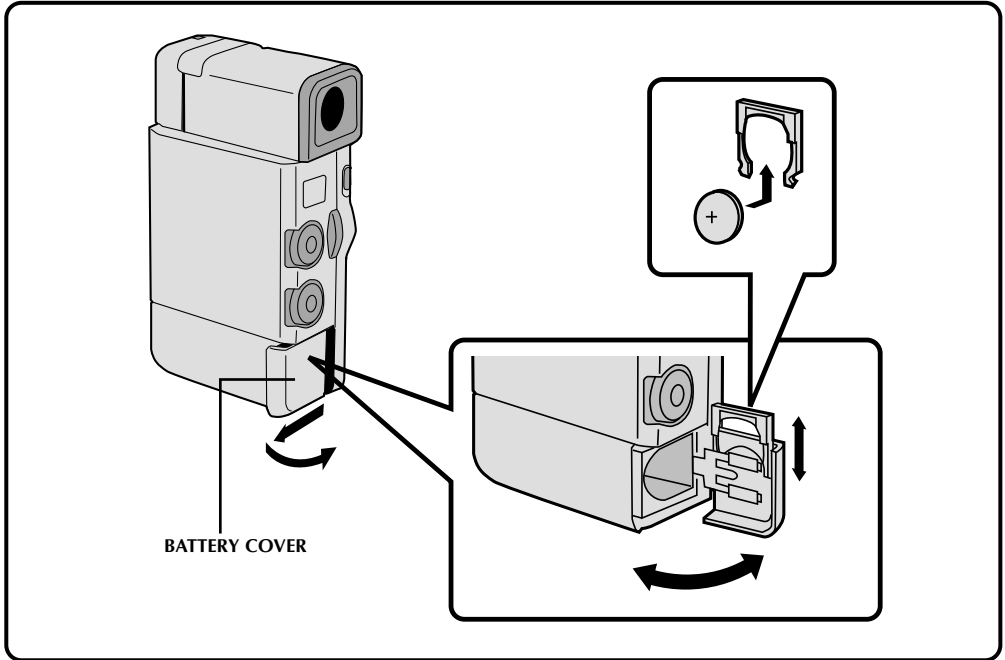

- 1 OPEN BATTERY COVER**
Slide off as shown in the illustration.
- 2 REMOVE OLD BATTERY**
Pull the battery holder out as shown, and slide the battery down and out of the holder.
- 3 INSERT NEW BATTERY**
Insert the battery, with the "+" side showing, in the holder. Then insert the battery holder in the battery cover.
- 4 CLOSE BATTERY COVER**

NOTES:

- When the battery is depleted, the "⏻" indicator appears in the viewfinder after you turn the power on.
- See "SAFETY PRECAUTIONS" on page 2 – 4 for information on safe handling of lithium batteries.
- After changing the lithium battery, reset the date and time (☰ pg. 12).

Date/Time Settings

If you set the date and time beforehand, the data will automatically be recorded separately from the video signal.

Even if the date and time do not appear during recording, you can display them on the screen or remove them from the screen at any time during playback.

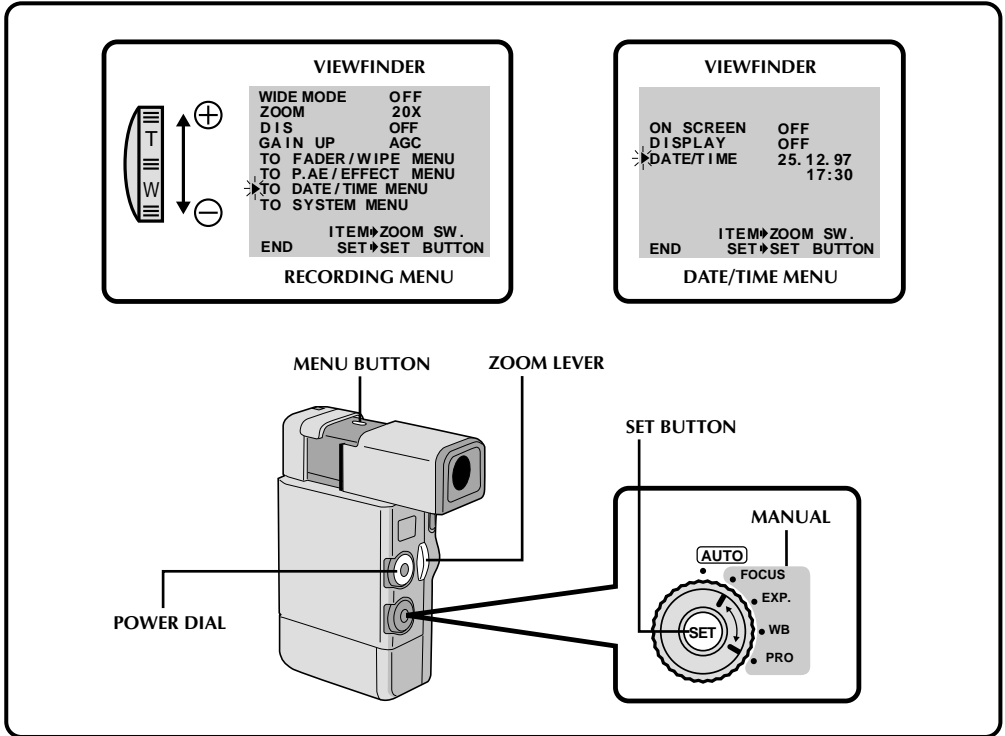

1 SELECT OPERATION MODE

Set the Power Dial to "REC" and the Select Dial to "MANUAL".

2 ACCESS RECORDING MENU

Press **MENU**. The Recording Menu appears in the viewfinder.

3 ACCESS DATE/TIME MENU

Place the pointer next to "TO DATE/TIME MENU" by sliding the Zoom Lever. Slide toward "+" to move up and toward "-" to move down. Press **SET** and the Date/Time Menu appears in the viewfinder.

4 INPUT DATE AND TIME

Place the pointer next to "DATE/TIME" by sliding the Zoom Lever. Press **SET** and "Day" begins blinking.

Using the Zoom Lever (slide toward "+" to increase and toward "-" to decrease), input the day. Press **SET**. Repeat the procedure to input the month, year, hour and minute. Press **SET** when the pointer is next to "END" to exit.

NOTE:

If you don't exit the Date/Time Menu, the clock display will not move but the camcorder's internal clock continues to operate. Once you close the menu, the date and time in the viewfinder begin operation from the current date and time, with no delay or loss.

Loading/Unloading A Cassette

If you have already installed a fully charged battery, you can open the door without external power.

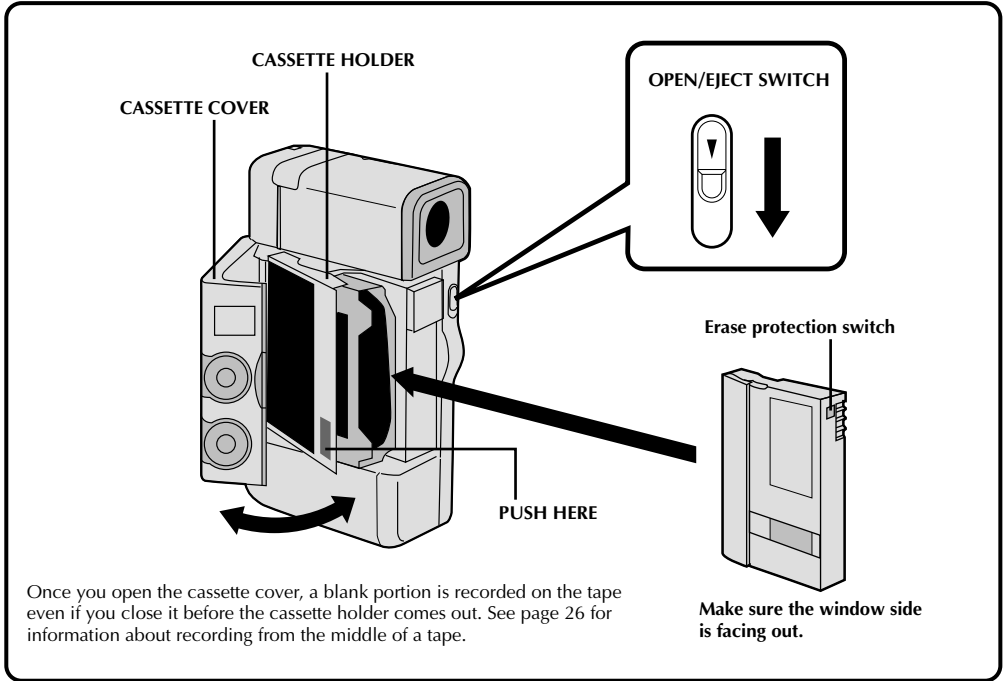

1 OPEN CASSETTE DOOR

Turn on the power, then slide the OPEN/EJECT switch in the direction of the arrow. The cassette cover releases. Open the cover in the direction of the arrow until it locks. The holder opens automatically.

- Do not touch internal components.

2 INSERT/REMOVE TAPE

Insert or remove a tape and press "PUSH HERE" to close the cassette holder.

- **Once the cassette holder is closed, it recedes automatically. Wait until it recedes completely before closing the cassette cover.**
- When the battery's charge is low, you may not be able to close the cover. Do not apply force. Replace the battery with a fully charged one before continuing.

NOTES:

- It takes a few seconds for the cassette holder to open. Do not apply force.
- If you wait a few seconds and the cassette holder doesn't open, close the cassette cover and try again.
- Be careful not to get your fingers caught in the holder when it's closing. If this happens, the holder will open automatically after a few seconds.
- When the camcorder is suddenly moved from a cold place to a warm environment, wait a short time before opening the cover.

** To protect valuable recordings . . .

..... slide the erase protection switch on the back of the tape in the direction of "SAVE". This prevents this tape from being recorded over. If you decide later that you do want to record on this tape, slide the switch back to "REC" before loading the tape.

TAPE	RECORDING TIME
DVM 30	Approx. 30 min.
DVM 60	Approx. 60 min.

Hand Strap Attachment

The provided Hand Strap helps you to keep a firm hold on the camcorder. Make sure you never hold the camcorder without using the Hand Strap.

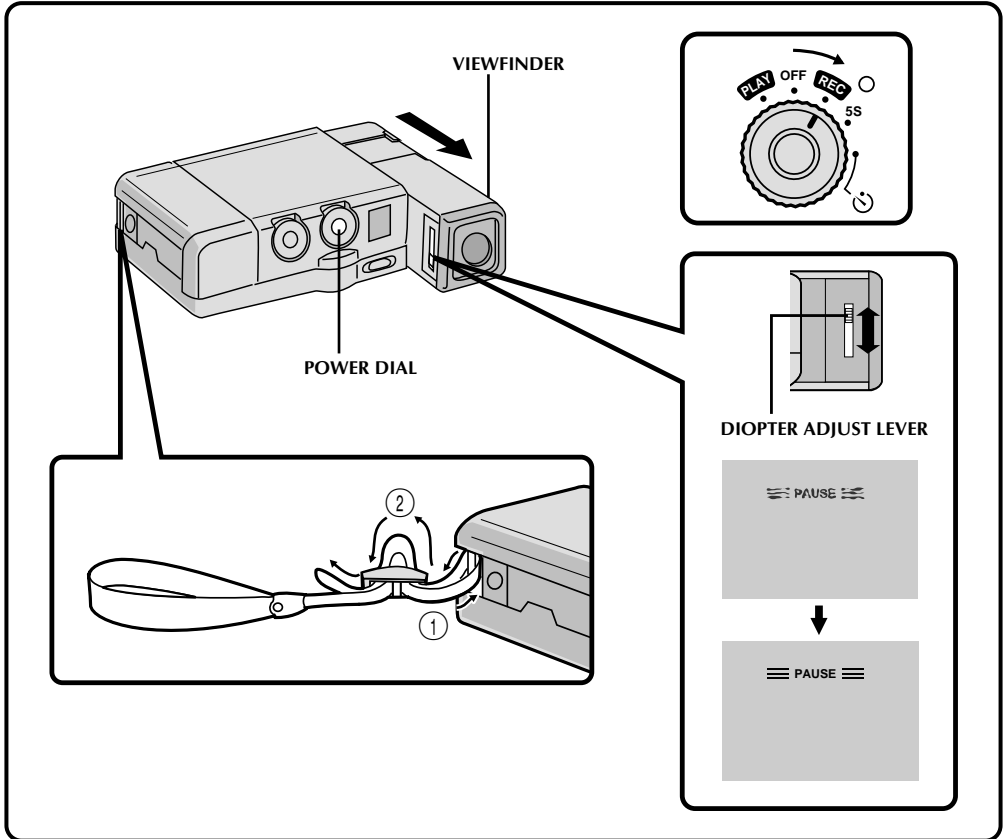

1 ATTACH HAND STRAP

Slide the strap through the eyelet, pulling firmly to ensure secure attachment.

1 SELECT OPERATION MODE

Set the Power Dial to "REC".

2 ADJUST DIOPTER

Pull out the viewfinder and slide the Diopter Adjust Lever.

- Slide in either direction, while looking at the viewfinder display, until it looks best to you.

Remote Control Unit (optionally available accessory kit CU-V70KIT E)

You can use the RM-V708U or RM-V710U to control the camcorder when it's attached to the Docking Station.

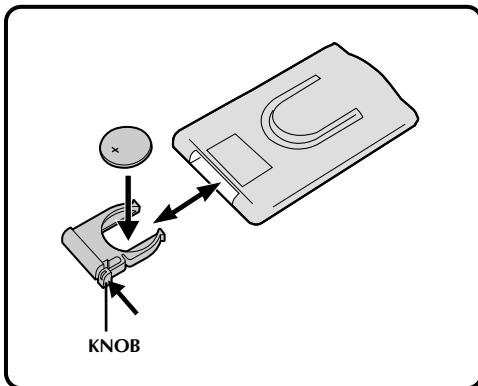
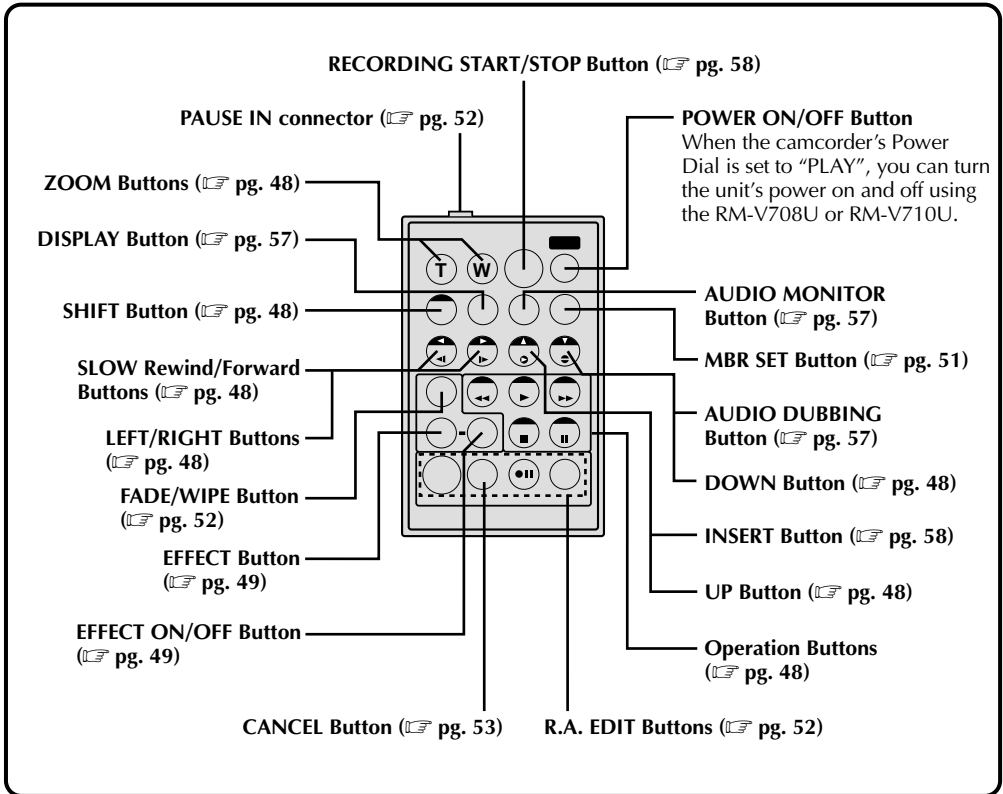

Installing The Battery

The RM-V708U or RM-V710U uses one lithium battery (CR2025).

- 1 PULL OUT BATTERY HOLDER**
Pull out in the direction of the arrow while pressing the lid as shown.
- 2 INSERT BATTERY IN HOLDER**
With the "+" side up, place the lithium battery (CR2025) in the holder.
- 3 RE-INSERT HOLDER**
Slide the holder back in until you hear a click.

Full Auto/Manual Operation

The following chart shows you which functions are available in the Full Auto and Manual operation modes.

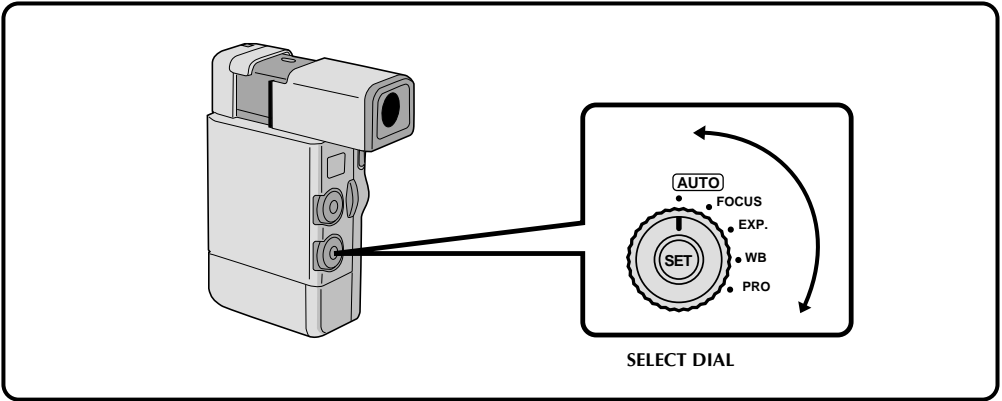

	FULL AUTO MODE	MANUAL MODE			
	SELECT DIAL POSITION	SELECT DIAL POSITION			
	AUTO	FOCUS	EXP.	WB	PRO
Snapshot (☞ pg. 23)	YES	YES	YES	YES	YES
Scene (☞ pg. 20)*2	YES*1	YES	YES	YES	YES
Self-Timer (☞ pg. 26)	YES	YES	YES	YES	YES
Date/Time Display (☞ pg. 28)	ON	ON/OFF	ON/OFF	ON/OFF	ON/OFF
Focus (☞ pg. 37)	AUTO	AUTO/MAN	AUTO/LOCK	AUTO/LOCK	AUTO/LOCK
D.I.Stabilizer (☞ pg. 18)*3	Not operational	ON/OFF	ON/OFF	ON/OFF	ON/OFF
Exposure Control (☞ pg. 38)	AUTO	AUTO/LOCK	AUTO/MAN	AUTO/LOCK	AUTO/LOCK
White Balance (☞ pg. 40)	AUTO	AUTO/LOCK	AUTO/LOCK	AUTO/MAN	AUTO/LOCK
Digital Zoom (☞ pg. 24)	20x only	ON/OFF	ON/OFF	ON/OFF	ON/OFF
P.AE/Effects (☞ pg. 34)	Not operational	YES (can't change once set)			YES
FADER/WIPE (☞ pg. 29)	Not operational	YES (can't change once set)			YES

*1- Factory-preset for "5S". However, if you change the setting in the System Menu (☞ pg. 19), either "5SD" or "ANIMATION" becomes available when you engage the "AUTO" mode.

*2- Records in "AUTO" regardless of Select Dial setting.

• Make sure the Power Dial is in the "MANUAL" position when you make selections at the Recording Menu.

*3- When D.I.Stabilizer is set to "ON", the shutter speed is automatically set to 1/100.

Menus

The Recording Menu allows you to set these functions: *Squeeze*, *Zoom Magnification*, *Digital Image Stabilizer*, *Gain Up*, *Fade/Wipe* (☞ pg. 29), *P.AE/Effects* (☞ pg. 34), *Date/Time Menu*, and *System Menu*. The following selection procedure applies to *Squeeze*, *Zoom Magnification*, *Stabilization* and *Gain Up*.

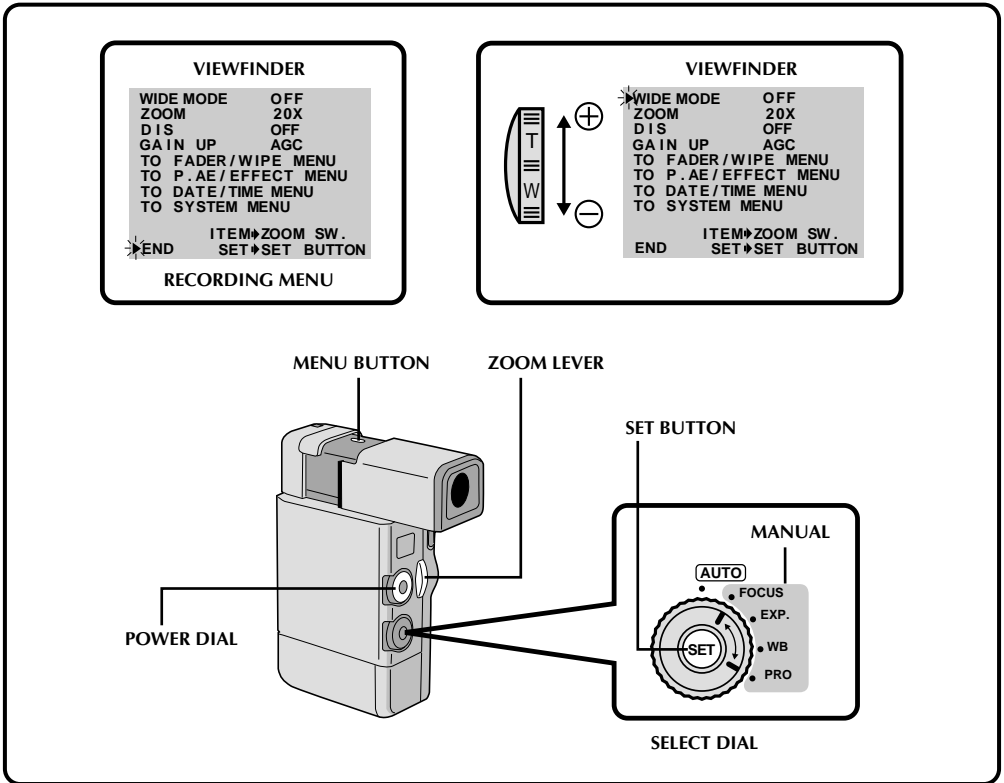

- 1 SELECT OPERATION MODE**
Set the Power Dial to "REC" and set the Select Dial to "MANUAL".
- 2 ACCESS RECORDING MENU**
Press MENU. The Recording Menu appears in the viewfinder.
- 3 SELECT FUNCTION**
Place the pointer next to the desired function by sliding the Zoom Lever, then press SET. The pointer stops blinking, indicating that the function has been selected.

- 4 SET FUNCTION PARAMETERS**
Cycle through the available settings of the selected functions by sliding the Zoom Lever in either direction, and stop when the one you want is displayed. Then press SET and the pointer automatically moves to "END".
 - 5 CLOSE RECORDING MENU**
Press SET. Selection is complete and the menu disappears.
- To set the parameters for a different function, repeat steps 3 and 4.

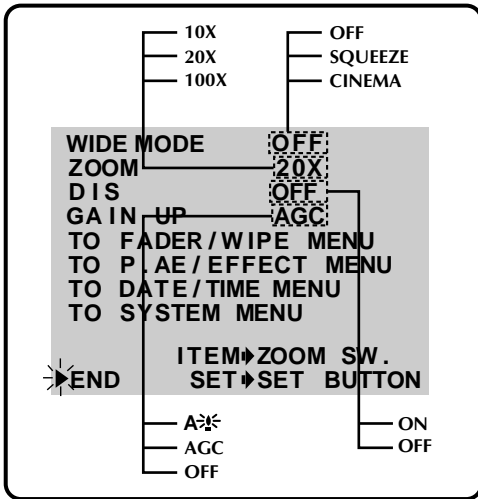

Wide Mode

This recording mode is compatible with wide-screen TVs (16:9 aspect ratio). When using this mode, please refer to your wide-screen TV's instruction manual.

SQUEEZE—For playback on TVs with an aspect ratio of 16:9. Naturally expands the image to fit the screen without distortion. appears in the viewfinder.

CINEMA—Inserts black bands at the top and bottom of the screen. Works with both 4:3 and 16:9 TVs. Used with the Sepia (pg. 35) or Monotone (pg. 35) modes, it gives the recorded scenes the look of a classic movie.

OFF—Select “OFF” when you don’t want to use either of the above modes (first set the Select Dial to “MANUAL”). *During Full-Auto operation, both Squeeze and Cinema modes are unusable.

When you watch a “SQUEEZE”- or “CINEMA”-mode picture on a wide-screen TV, connect an S-Video cable between connector S1 or S2 on the TV and the S-Video output connector on the Docking Station, and adjust the setting at the TV manually to produce the appropriate 16:9 picture.

During playback, the images is naturally expanded to fit the wide screen, with no proportional distortion.

NOTES:

- When recording using the Squeeze, the image in the viewfinder, as well as on a regular TV (if connected for playback) will be the standard aspect ratio and the picture will appear squeezed.
- When playing back a tape recorded in Squeeze and Cinema, Squeeze cannot be distinguished from Cinema during fast-forward or rewind.

DIS (Digital Image Stabilizer)

When recording while holding the camcorder in your hand, or when shooting a subject with little or no contrast, subtle hand movements will cause shakiness in the recorded image.

ON—Compensates for relatively small shakes that occur when shooting close up. “” appears in the viewfinder during recording. *This function is usable when the Select Dial is set to “MANUAL”.

OFF—When shooting with the camcorder in a fixed position or on a tripod, set the Stabilizer to “OFF”. If you leave it on and then move or turn the camera to follow a moving subject, unnecessary compensation occurs and this can result in an unnatural recorded image.

NOTES:

- The Stabilizer cannot compensate for drastic hand movements while shooting.
- The Stabilizer will not work when certain P.AE/Effects (Classic Film, Strobe, Slow 1, 2 (pg. 35) and Fade/Wipe Effects (Picture Wipe/Dissolve (pg. 31) are activated. The “” indicator appears blinking in the viewfinder.

Zoom Magnification

You can select 10x, 20x, or 100x zoom magnifications.

10x—Optical zoom that does not degrade the quality of the recording.

20x—Electronic processing (Digital zoom) that lets you get closer up.

100x—Electronically-processed images at 100-times magnification.

Gain Up

Bright, natural recordings can be taken even in areas with low or poor lighting.

A $\frac{1}{25}$ —The shutter speed is automatically adjusted (1/25 — 1/200 sec.). Shooting a subject in low or poor lighting at 1/25 sec. shutter speed provides a brighter image than in the AGC mode, but the subject’s movements are not smooth or natural.

OFF—Select this setting when lighting is not a problem.

AGC—This is the factory setting, and is automatically activated during Auto operation. The overall appearance is jagged, but the image is bright and the movements are more natural than in “A $\frac{1}{25}$ ” mode.

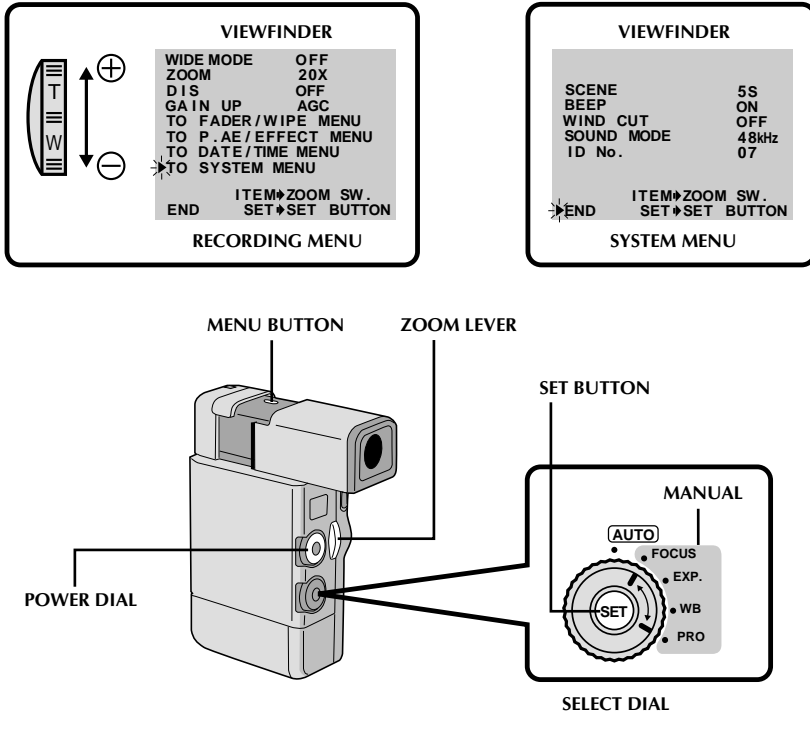

System Menu

The System Menu allows you to set the following functions: *Scene, Beep, Wind Cut, Sound Mode and ID numbers.*

- 1 SELECT OPERATION MODE**
Set the Power Dial to "REC" and set the Select Dial to "MANUAL".
- 2 ACCESS RECORDING MENU**
Press **MENU**. The Recording Menu appears in the viewfinder.
- 3 ACCESS SYSTEM MENU**
Place the pointer next to "TO SYSTEM MENU" by sliding the Zoom Lever, then press **SET**. The System Menu appears in the viewfinder.
- 4 SELECT FUNCTION**
Place the pointer next to the desired function by sliding the Zoom Lever, then press **SET**. The pointer stops blinking, indicating that the function has been selected.

- 5 SET FUNCTION PARAMETERS**
Slide the Zoom Lever in either direction to cycle through the available settings for the selected function, and stop when the desired setting appears. Then press **SET**, and the pointer automatically moves to "END".
 - To set the parameters for a different function, repeat steps 4 and 5.
- 6 CLOSE SYSTEM MENU**
Press **SET** twice. Setting is complete and the System Menu disappears.

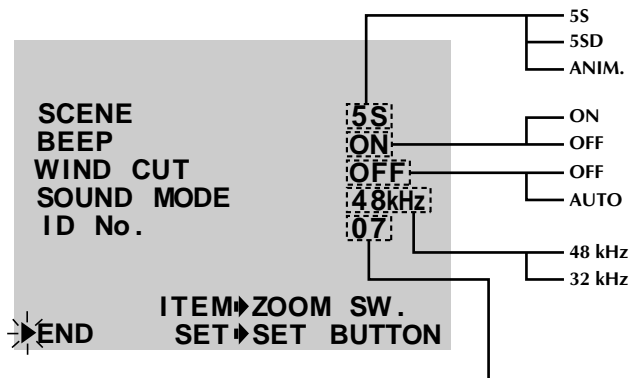

Sound

Sound signals can be sampled at 48 kHz or 32 kHz.

48 kHz—The camcorder is factory-preset for 48 kHz. This setting enables recording of stereo sound on two separate channels. *A tape recorded at 48 kHz cannot be used for Audio Dubbing.

32 kHz—This setting enables recording of stereo sound on four separate channels, and is recommended for use when performing Audio Dubbing.

Scene (5-Second Mode)

This mode is enabled when the Power Dial is set to "5S".

5S—Pressing **RECORDING START/STOP** allows you to take a 5-second "clip". Press repeatedly for a succession of short recordings.

5SD—If you record a 5-second clip within 5 minutes after the previous one, the end of the old scene dissolves and is replaced by the new scene over a 2-second period (see pg. 25).

ANIM. (Animation)—Each time you press **RECORDING START/STOP**, a 1/8-second recording is taken. By using an inanimate object and changing its position between shots, you can record the subject as though it's moving.

Beep

The beep sounds when the power is turned on or off, and at the beginning and end of recording.

ON—To activate the beep.

OFF—To turn off the beep.

NOTE:

Beep is automatically turned on during Full Auto operation.

Wind Cut

When activated, this mode helps cut down on noise created by wind.

AUTO—When shooting in high winds, noise is automatically reduced.

- "⚡" appears in the viewfinder.
- The quality of the sound will change. This is normal.

OFF—This function is disabled.

NOTE:

The Wind Cut mode is disabled during Full Auto operation.

Basic Recording

You should already have performed the necessary preparations (☞ pgs. 8 – 20). Set the Select Dial to “AUTO” and try recording that way before attempting to use more advanced features.

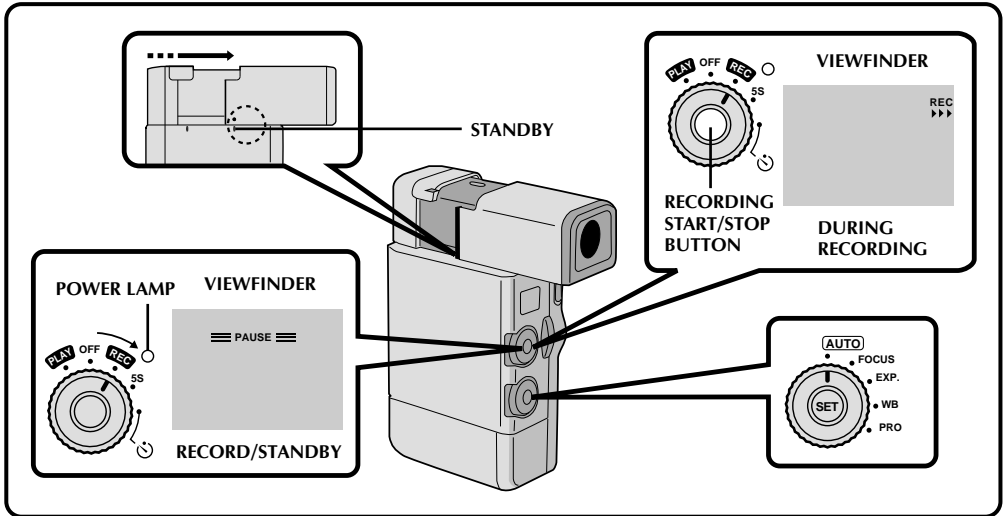

NOTE:

Before starting recording, make sure you set the date and time (☞ pg. 12). Even if they don't appear during recording, they are recorded onto the tape and can be displayed during playback. (☞ pg. 47).

1 PULL OUT VIEWFINDER

Align its mark with “STANDBY”.

2 TURN ON POWER

Set the Power Dial to “REC”. The power lamp comes on and RECORD/STANDBY mode is engaged.

- If you don't pull out the viewfinder, the power cannot be turned on.

3 SELECT OPERATION MODE

Set the Select Dial to “AUTO”.

- In the “AUTO” mode, only Zoom (20x), Snapshot, 5S (if you change the setting in the System Menu, either 5SD or ANIMATION becomes available – see pgs. 19 – 20) and Self-Timer are available.

4 START RECORDING

When “PAUSE” appears in the viewfinder, press **RECORDING START/STOP**. A beep signals the start of recording.

5 END RECORDING

When you're finished recording, press **RECORDING START/STOP**. Align the viewfinder's mark with “CAMERA OFF”; the power lamp goes out and the lens cover closes automatically.

- When transporting, make sure the viewfinder is in this position.
- Before turning the power on again, you must pull out the viewfinder.

NOTES:

- If 5 minutes elapse in the RECORD/STANDBY mode, the power shuts off automatically to conserve energy. To turn the camcorder on again, set the Power Dial to “OFF”, then to “REC”. As long as you don't take out the tape you were using or play it back, you can continue recording from where you left off with no noticeable break.
- RECORD/STANDBY means that a tape is loaded and the camcorder is ready to record.
- If RECORD/STANDBY is engaged for 5 minutes, the Stop mode is automatically activated to protect the heads.
- If you start a recording on a blank portion of the tape, or onto a brand new tape, recording starts approximately 3-4 seconds after you press **RECORDING START/STOP**. In order to record the entire scene or sequence, make sure to start recording slightly in advance.

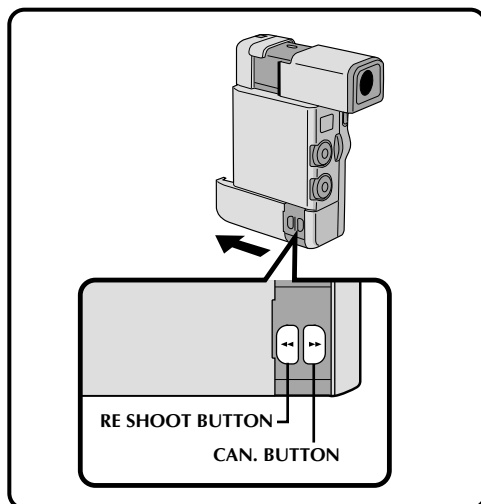
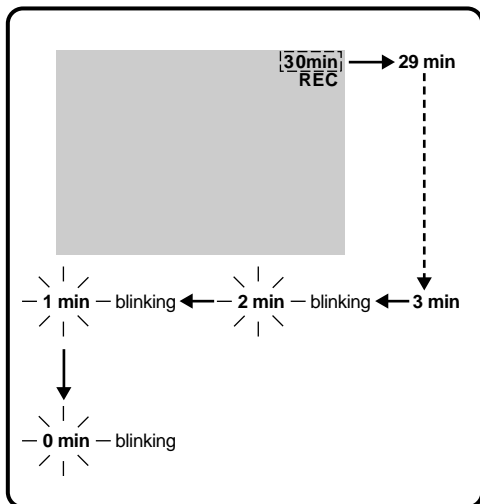

Tape Remaining Indicator

The time remaining on the tape is automatically monitored and displayed in the viewfinder (▶ pg. 64). When the tape ends, "TAPE END" appears in the viewfinder.

Re Shoot A Scene

If you aren't pleased with a scene you just recorded (after having checked it in the viewfinder), you can easily return to the beginning and record it again.

1 ENGAGE RECORD/STANDBY MODE
Press **RECORDING START/STOP**, then press **RE SHOOT**. The tape returns automatically to the starting point of the most recent recording, and the camcorder enters RECORD/STANDBY mode.

- If, after the tape has rewound to the beginning of the scene, you decide you don't need to re-record, press **CAN.** The tape automatically fast-forwards to the end of the scene.

Stable Shooting Positions

Before pressing **RECORDING START/STOP**, **ZOOM** or **SNAPSHOT**, be sure to hold the camcorder with both hands.



For low shooting

Feet set slightly apart with your body turned toward the subject

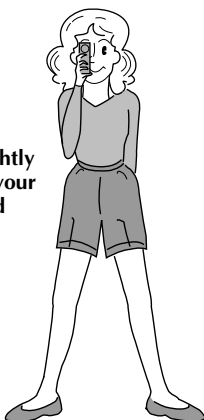

Fasten hand strap around wrist

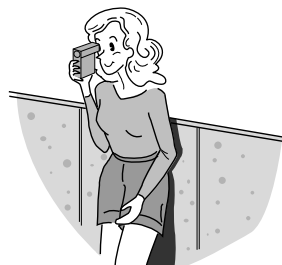

Lean against a wall or pole for support

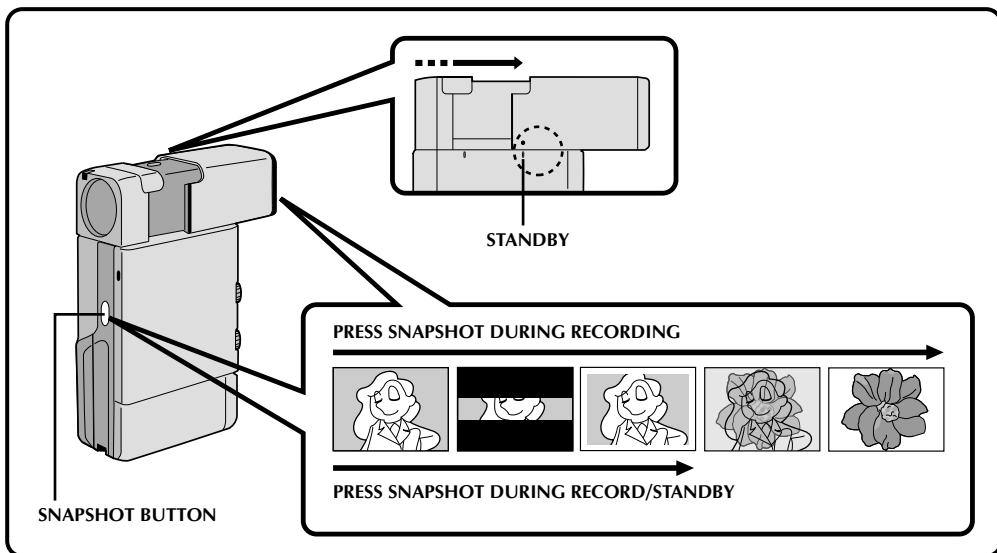

Snapshot

Use your camcorder like a regular camera and take a snapshot, or several of them in succession.

1 PULL OUT VIEWFINDER

Align its mark to "STANDBY". The lens cover opens automatically.

2 TAKE SNAPSHOT

Press **SNAPSHOT**. "PHOTO" appears in the viewfinder, and the image, bordered by a white frame, will be recorded and displayed in the viewfinder for 6 seconds. The next image then gradually overlaps the snapshot and normal recording resumes.

- When using the Snapshot function from RECORD/STANDBY, the camcorder returns to RECORD/STANDBY after 6 seconds.
- The sound effect of a shutter closing is recorded together with the image.

Motor Drive mode:

Keeping **SNAPSHOT** pressed provides an effect similar to serial photography. (The interval between the still pictures: approx. 0.7 seconds)

Snapshot Search

The Snapshot Search function enables you to quickly and easily access scenes recorded in the Snapshot mode, or scenes where Strobe (pg. 35) was used.

1 ENABLE SNAPSHOT SEARCH

Set the Power Dial to "PLAY".

2 REWIND TAPE

Press **REW**. Let the tape rewind to the beginning, where it stops automatically.

3 BEGIN SEARCH

Press **SNAPSHOT**. The camcorder begins searching for the first scene recorded in Snapshot mode or where the Strobe effect was used.

- If the first scene on the tape was recorded in Snapshot mode or with the Strobe effect, the camcorder may not be able to locate the exact beginning of the scene.

Snapshot Search could malfunction if the recorded tape has:

- Too little time between Snap shots
- Blank space between recordings
- Snap shots taken using Motor Drive mode

To Stop A Snapshot Search In Progress . . .

..... press **SNAPSHOT** again.

NOTES:

- To temporarily stop playback, press **PAUSE**. This is known as "still playback". Press again to resume normal playback. If still playback continues for more than about 3 minutes, the camcorder's Stop mode is automatically engaged. If the camcorder is left in its Stop mode for 5 minutes, its power goes off automatically.
- In the future, by attaching the camcorder to the Docking Station and connecting a video printer to the station, it will become possible to print out snapshots.

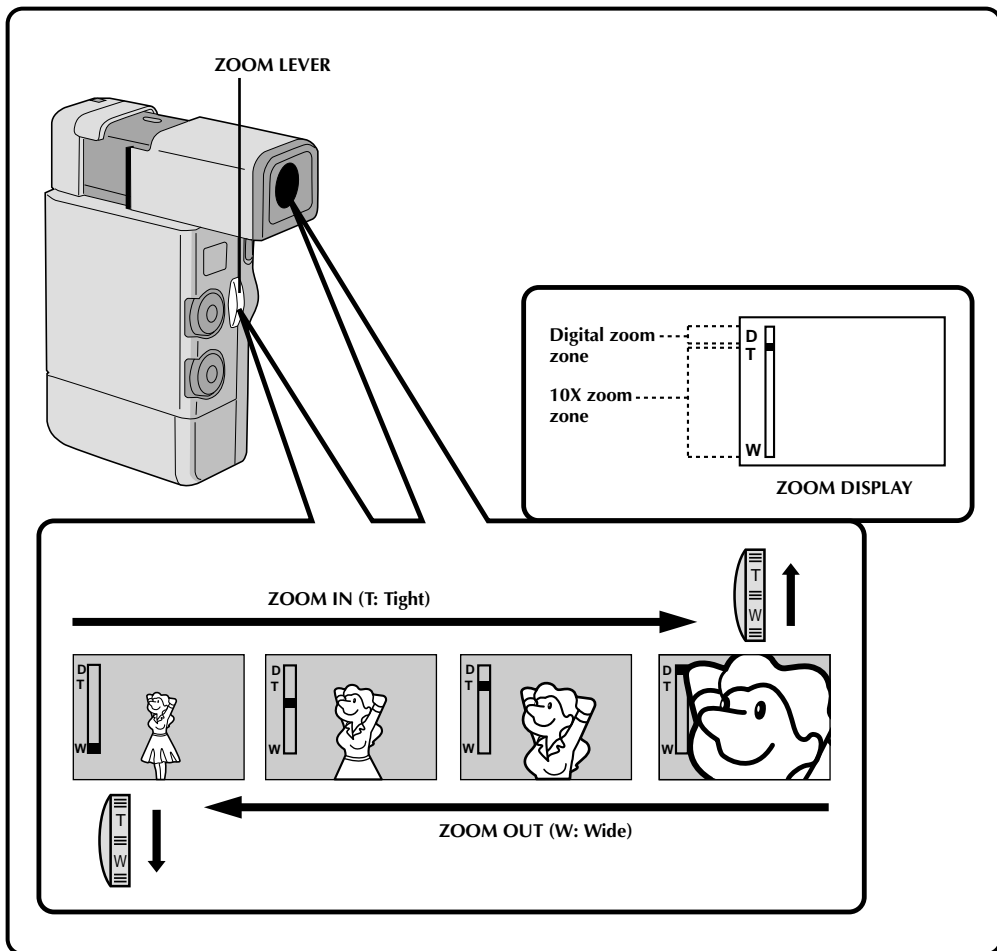

Zoom

Select any one of the three powers of magnification and get “closer” to the subject (☞ pg. 18).

Simply slide the Zoom Lever to either zoom in (toward “+”) or zoom out (toward “-”). The Zoom speed is variable — the quicker you slide the Zoom Lever, the quicker the zoom action.

NOTE:

Digital zoom (20x and 100x) cannot be used while the Video Echo effect (☞ pg. 35), the Picture Wipe/ Dissolve function (☞ pg. 31) or the 5SD mode (☞ pg. 25) are activated.

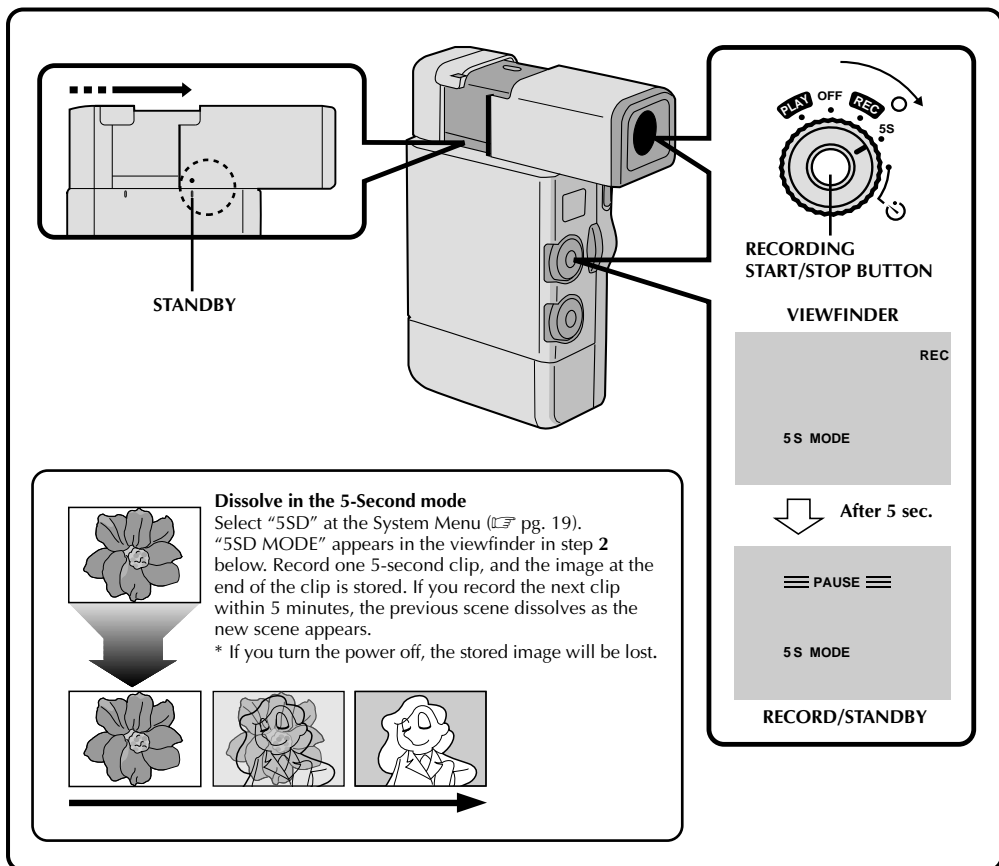

Scene

Record a vacation or an important event in 5-second clips to keep the action moving. The 5-Second function may also be activated during Full Auto operation. While the 5-Second mode is activated, Fade/Wipe (pg. 29), P.AE/Effects (pg. 34) and other manual operations cannot be performed.

1 PULL OUT VIEWFINDER

Align its mark to "STANDBY". The lens cover opens automatically.

2 SELECT MODE

Set the Power Dial to "5S" and press **RECORDING START/STOP**. "5S MODE" appears in the viewfinder, the tally lamp lights to indicate the start of recording, and after 5 seconds the camcorder enters RECORD/STANDBY mode.

- If you press and hold **START/STOP** within 5 seconds after recording starts, RECORD/STANDBY is not engaged.

3 END 5-SECOND MODE RECORDING

When you're done, set the Power Dial to the "REC" or "OFF" position.

To Take A Snapshot In The 5-Second Mode . . .

.... instead of pressing **RECORDING START/STOP** in step 2, press **SNAPSHOT**. The camcorder records a 6-second still with the shutter sound, but without the white border.

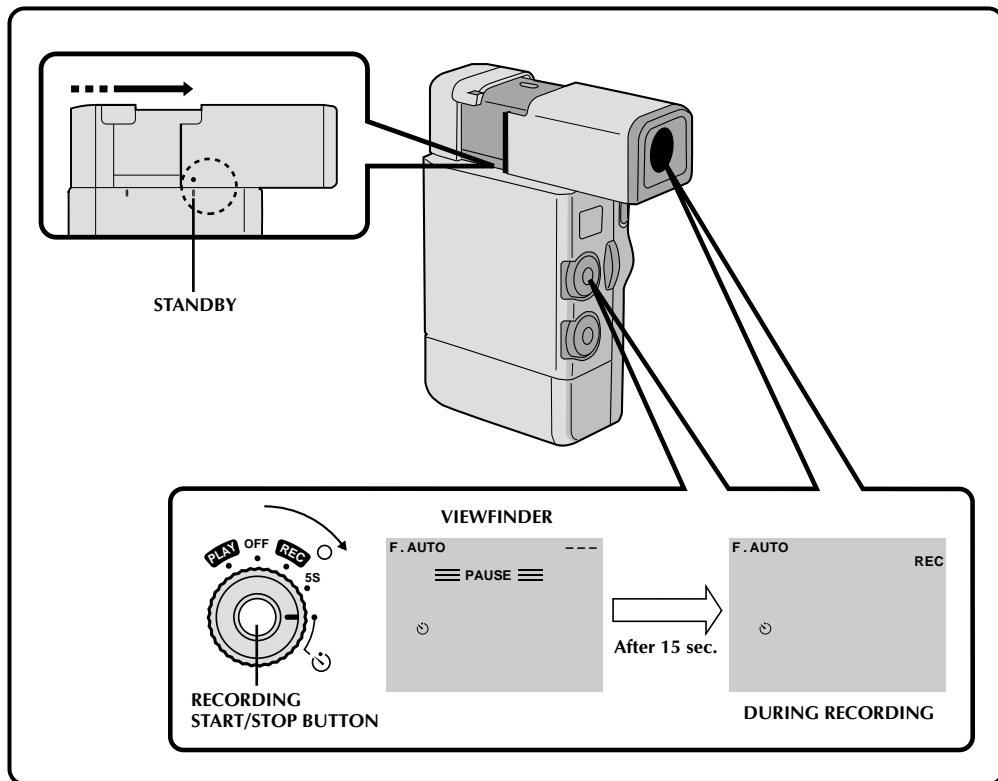

Self-Timer

Once the camcorder is set, you (or whomever is operating the camcorder) can get into the scene, putting the final touch on a memorable picture.

1 PULL OUT VIEWFINDER
Align its mark to "STANDBY". The lens cover opens automatically.

2 SELECT MODE
Set the Power Dial to "☺" and press **RECORDING START/STOP**. "☺" appears in the viewfinder, and the tally lamp lights and begins blinking 15 seconds before recording starts. When the lamp stops blinking, recording begins.

3 END RECORDING
Press **RECORDING START/STOP** and set the Power Dial to the "REC" or "OFF" position.

To Take A Snapshot In The Self-Timer Mode . . .
..... in step 2, press **SNAPSHOT** instead of **RECORDING START/STOP**. After 15 seconds, a 6-second still with the shutter sound effect and a white border is recorded. After that, the camcorder enters the RECORD/STANDBY mode.

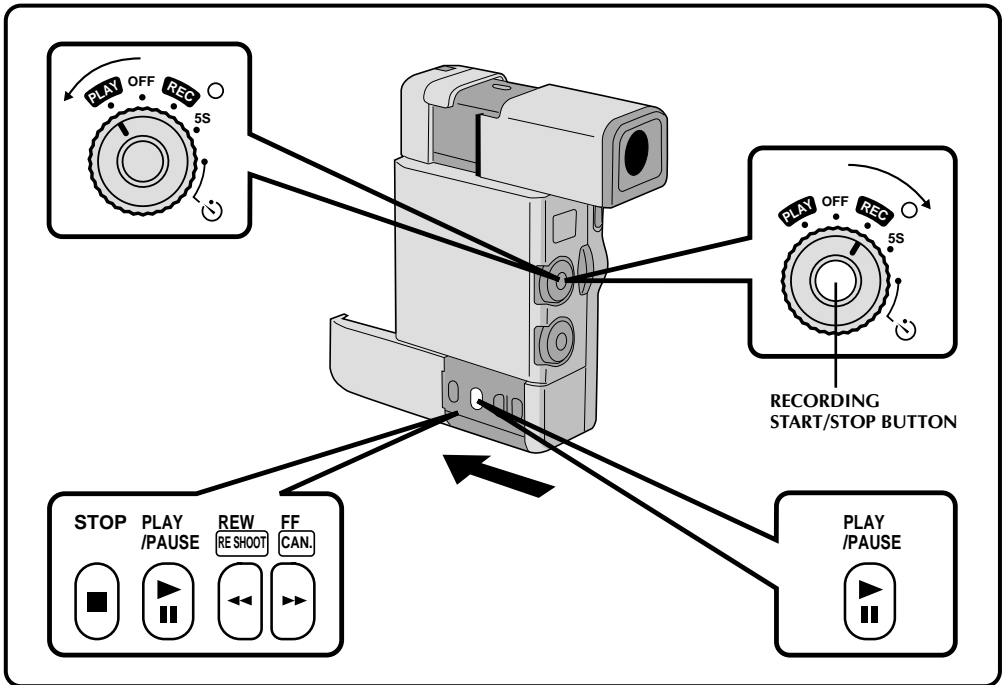

Recording From The Middle Of A Tape

When removing a tape on which you were recording, or when you resume recording on a tape after playing back the recording previously made (without taking the tape out between recordings), perform this procedure.

- 1 SELECT MODE**
Set the Power Dial to "PLAY".
- 2 START SEARCH**
Press **PLAY**, then press **REW** or **FF**. Watch in the viewfinder for the spot where you want to begin recording.
- 3 ENGAGE STILL MODE**
Once you find the spot at which you want to start recording, press **PLAY/PAUSE** to engage the Still mode.
- 4 START RECORDING**
Set the Power Dial to "REC" and press **RECORDING START/STOP**.

NOTES:

- Starting at 00:00:00 (MIN:SEC:FRAME), the camcorder records a time reference signal from the beginning of the tape. See page 47 for information about displaying Time Codes.
The video recording may not start from exactly 00:00:00.
- The Time Code cannot be reset.
- If you start recording from the end of the previous recording leaving no blank space, there may be situations where a clean transition is not possible.
- Whenever you start recording in a blank portion, the Time Code counts from 00:00:00. That means the camcorder may record the same Time Codes as a previously-recorded segment. Random Assemble Editing (pg. 52) may not function properly when using a tape with duplicated codes. To prevent this, start recording from the end of the previous recording leaving no blank space. Note that such a blank space may be also left between scenes when a tape is removed and re-inserted.
- Even if you record over the blank space between two already-recorded segments, the old Time Codes remain after the newly-recorded portion, and thus duplicated codes will still exist. Random Assemble Editing (pg. 52) may not function properly in the case.

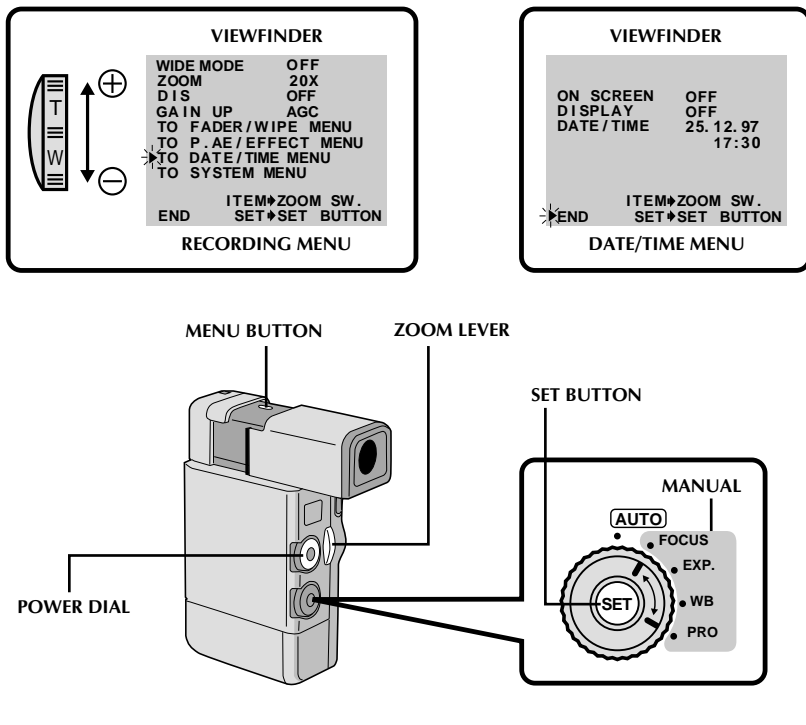

Displaying The Date And Time During Recording

You must first set the date and time (see "Date/Time Settings" pg. 12). Set "DISPLAY" to "ON" in the Date/Time Menu. The Date/Time appears in the viewfinder if the Select Dial is set to "MANUAL". The Date/Time is always displayed in the viewfinder when the Select Dial is set to "AUTO".

1 SELECT OPERATION MODE

Set the Power Dial to "REC" and the Select Dial to "MANUAL".

2 ACCESS RECORDING MENU

Press **MENU**. The Recording Menu appears in the viewfinder.

3 ACCESS DATE/TIME MENU

Place the pointer next to "TO DATE/TIME MENU" by sliding the Zoom Lever. Slide toward "+" to move up and toward "-" to move down. Press **SET** and the Date/Time Menu appears in the viewfinder.

4 INPUT DATE AND TIME

Place the pointer next to "DISPLAY" by sliding the Zoom Lever, then press **SET**. The cursor stops blinking, indicating that the function has been selected.

5 SET FUNCTION PARAMETERS

Cycle through the available settings of the selected functions by sliding the Zoom Lever in either direction, and stop when the one you want is displayed. Then press **SET** and the pointer automatically moves to "END".

6 CLOSE RECORDING MENU

Press **SET** twice. Selection is complete and the menu disappears.

NOTE:

Connect the camcorder to a TV and set "ON SCREEN" to "ON" in the Date/Time Menu. The display appears on the connected TV when the camcorder is in RECORD/STANDBY.

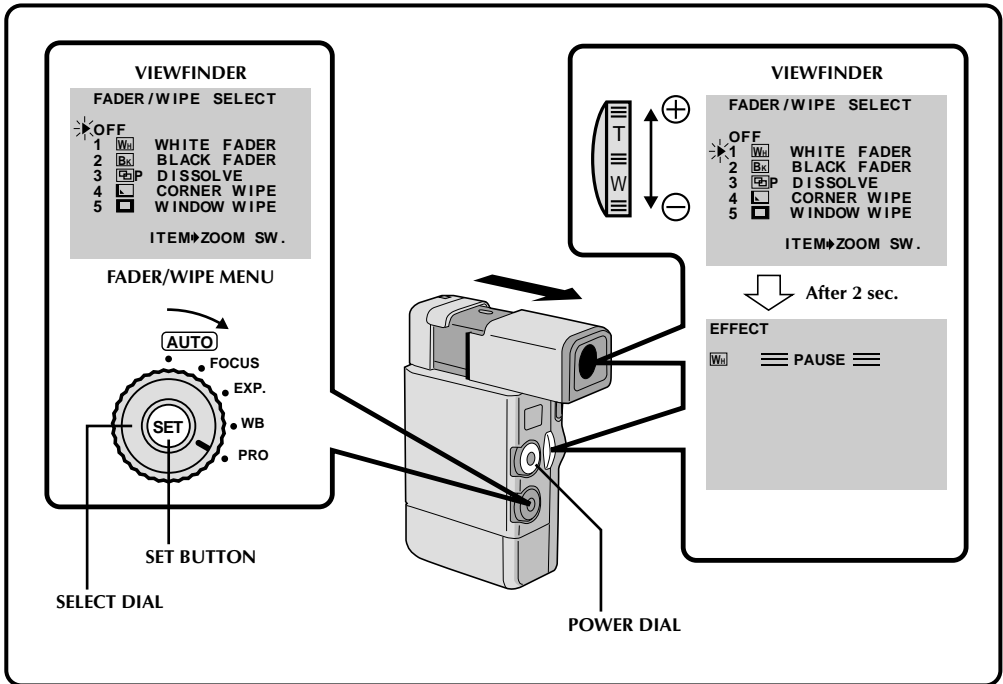

FADE/WIPE Effects

Use these to spice up the transition from one scene to the next. You can also vary transitions from scene to scene.

Select any one effect from the Fader/Wipe Menu. To use effects that don't appear in the menu, exchange them (☞ pg. 33).

1 SELECT OPERATION MODE
 Set the Select Dial to "PRO". "EFFECT" appears in the viewfinder.

2 ACCESS FADER/WIPE MENU
 Press SET. The Fader/Wipe Menu appears in the viewfinder.

3 SELECT EFFECT
 Place the pointer next to the desired effect by sliding the Zoom Lever.

- Once you select the desired effect, the Fader/Wipe Menu disappears and the effect is activated within 2 seconds. The indicator representing the selected effect appears in the viewfinder.

NOTE:

Refer to pages 30 – 32 for Fade/Wipe effects and techniques.

4 START RECORDING
 Press RECORDING START/STOP. The buzzer sounds, indicating the start of recording.

5 DEACTIVATE FADE/WIPE EFFECTS
 In step 3, place the pointer next to "OFF".

NOTES:

- If certain P.AE/Effects are activated, some Fade/Wipe Effects cannot be used. If you select a Fade/Wipe Effect that is unusable in the current situation, the indication blinks.
- The P.AE Effect Menu is displayed if SET is pressed twice. Press SET again to display the Fader/Wipe Menu.
- Keep SET pressed to continue displaying the menu until you make your selection using the Zoom Lever.
- Beep won't sound when the Select Dial is set to "MANUAL" (☞ pg. 19) if "BEEP" is set to "OFF" in the System Menu.

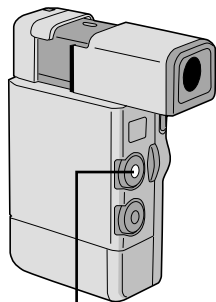

RECORDING
START/STOP BUTTON

FADE

EXAMPLE  **WHITE FADER**

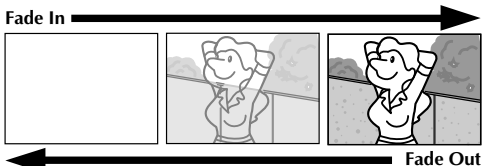

WIPE

EXAMPLE  **SCROLL WIPE**

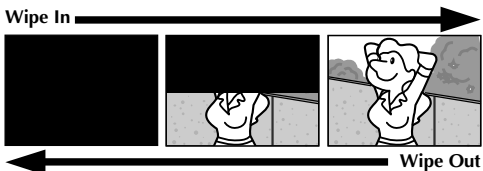

Fades and Wipes

A scene gradually appears on a black or white screen (Fade In/Wipe In), or disappears, leaving a black or white screen (Fade Out/Wipe Out). Select Fade or Wipe at the Fader/Wipe Menu ( pg. 29).

1 ACTIVATE FADE IN OR WIPE IN

Press **RECORDING START/STOP** to start recording, and the Fade In or Wipe In occurs automatically.

2 ACTIVATE FADE OUT OR WIPE OUT

When you want to stop recording the scene, press **RECORDING START/STOP**. Before the camcorder enters the RECORD/STANDBY mode, the Fade Out or Wipe Out occurs automatically.

NOTE:

You can extend the length of a fade or wipe by pressing and holding the **RECORDING START/STOP** button.

 **WHITE FADER:**
Fade in or out with a white screen.

 **BLACK FADER:**
Fade in or out with a black screen.

 **BLACK & WHITE FADER:**
Fade in to a color screen from a black and white screen, or fade out from colour to black and white.

 **MOSAIC FADER:**
Fade in or out with a full-screen mosaic effect.

 **SHUTTER WIPE:**
Wipe in toward the centre of a black screen from the top and bottom, or wipe out from the centre toward the top and bottom, leaving a black screen.

 **SLIDE WIPE:**
Wipe in from right to left, or wipe out from left to right.

 **DOOR WIPE:**
Wipe in as the two halves of a black screen open to the left and right, revealing the scene, or wipe out and the black screen reappears from left and right to cover the scene.

 **CORNER WIPE:**
Wipe in on a black screen from the upper right to the lower left corner, or wipe out from lower left to upper right, leaving a black screen.

 **WINDOW WIPE:**
The scene starts in the centre of a black screen and wipes in toward the corners, or comes in from the corners, gradually wiping out to the center.

 **SCROLL WIPE:**
The scene wipes in from the bottom to the top of a black screen, or wipes out from top to bottom, leaving a black screen.

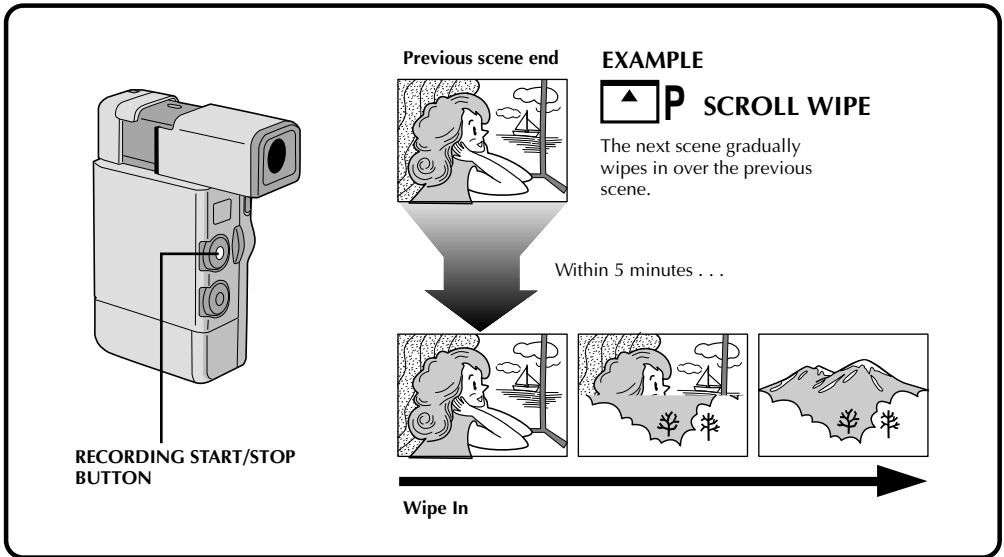

Picture Wipe/Dissolve

Combine the Picture Wipe and Dissolve functions for a professional transition effect. There are 6 Picture Wipe effects and 1 Dissolve effect. Select the Picture Wipe effect at the Fader/Wipe Menu (pg. 29). If you want to use effects not currently appearing on the menu, exchange those appearing for others (pg. 33).

1 START RECORDING
Press **RECORDING START/STOP**.

2 ENGAGE RECORD/STANDBY MODE
Press **RECORDING START/STOP** when one scene is finished. The point at which the scene ended is stored in memory.

3 RESUME RECORDING
If you start recording a new scene within 5 minutes of the end of the previous recording (without having turned the camcorder's power off), the previous scene wipes out from bottom to top, revealing the new scene.

NOTES:

- If you turn off the power after having finished recording a scene, the stored point is erased. This disables the Picture Wipe/Dissolve combination. When this happens, the Picture Wipe/Dissolve indicator blinks. Try recording again, but don't turn the power off when you're finished. The camcorder stores the end point of the last recorded scene, and you can use Picture Wipe/Dissolve between the last scene and the next one.
- The sound at the end of the last recorded scene is not stored.

◀ P SLIDE WIPE:
The next scene gradually wipes in over the previous one from right to left.

▶ P DOOR WIPE:
The previous scene wipes out from the centre to the right and left, like a door being pushed open to reveal the next scene.

◓ P CORNER WIPE:
The new scene wipes in over the previous one from the upper right corner to the lower left corner.

◑ P WINDOW WIPE:
The next scene gradually wipes in from the centre of the screen toward the corners, covering the previous scene.

▲ P SCROLL WIPE:
The new scene wipes in over the last one from the bottom of the screen to the top.

▲▼ P SHUTTER WIPE:
The new scene wipes in over the previous one from the centre toward the top and bottom of the screen.

◻ P DISSOLVE:
The new scene gradually appears as the old one gradually disappears.

RECORDING
START/STOP BUTTON

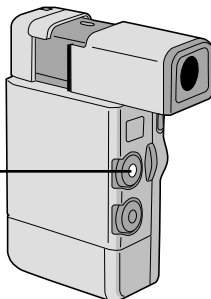

Random Variations



RANDOM FADER:

When this function is activated, the camcorder randomly selects the effect used in scene transition (from the Fade and Wipe effects).



The camcorder chooses one of the fades/wipes at random.

1

START RECORDING

Press **RECORDING START/STOP**, and “**?R**” appears in the viewfinder. The camcorder does the rest, selecting an effect at random.

- The recording starts with a Fade In or Wipe In. If you press **RECORDING START/STOP** during recording, RECORD/STANDBY mode is preceded by a Fade Out or Wipe Out; when you resume recording, it begins with a Fade In or Wipe In.

NOTES:

- The Picture Wipe/Dissolve feature is not available when Random Fader is activated.
- When using MOSAIC FADER, a black bar may appear at the bottom of the screen.

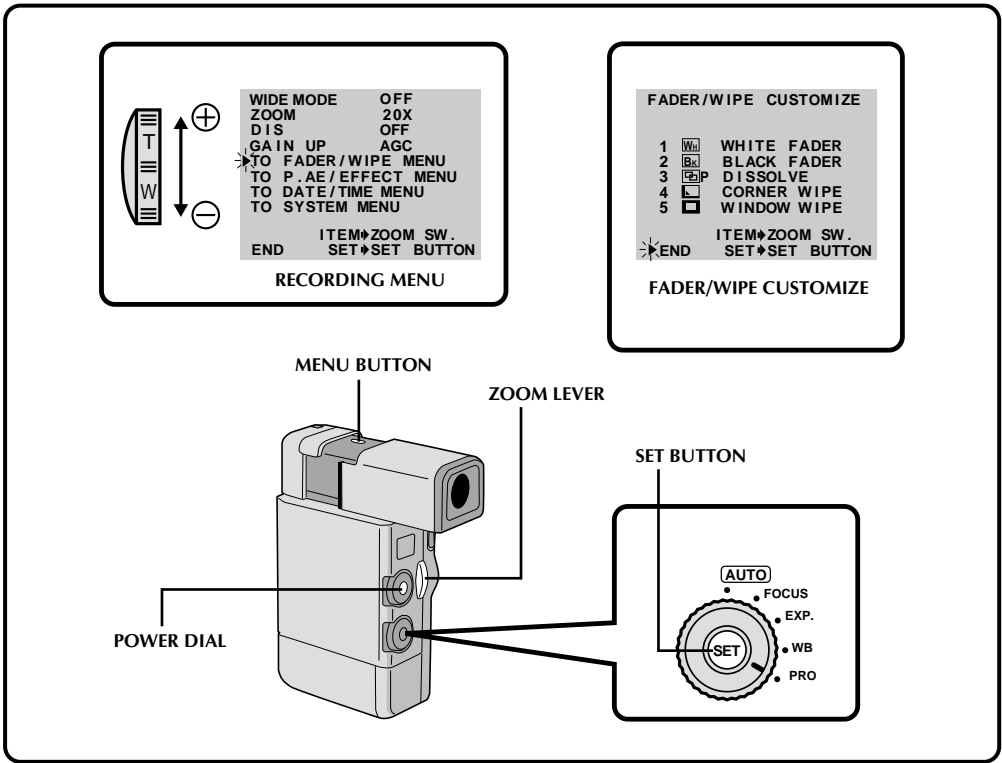

Exchanging FADE/WIPE Effects

You can replace the 5 effects currently appearing in the menu with 5 others. After exchanging, the new effects appear in the Fader/Wipe Menu.

1 SELECT OPERATION MODE

Set the Select Dial to "PRO".

2 ACCESS RECORDING MENU

Press **MENU**. The Recording Menu appears in the viewfinder.

3 ACCESS FADER/WIPE CUSTOMIZE MENU

Place the pointer next to "TO FADER/WIPE MENU" by sliding the Zoom Lever, then press **SET**. The Fader/Wipe Customize Menu appears.

4 SELECT EFFECT TO BE REPLACED

Place the pointer next to the number of the effect you want to replace by sliding the Zoom Lever, then press **SET**. The cursor stops blinking.

5 SELECT NEW EFFECT

Cycle through the remaining effects by sliding the Zoom Lever in either direction, and stop when the one you want is displayed. Press **SET**.

- The pointer automatically moves to "END".
- To replace other effects, repeat steps 4 and 5.

6 CLOSE MENU

Press **SET** twice. Selection is complete, and you can use the new effects during recording (pg. 29).

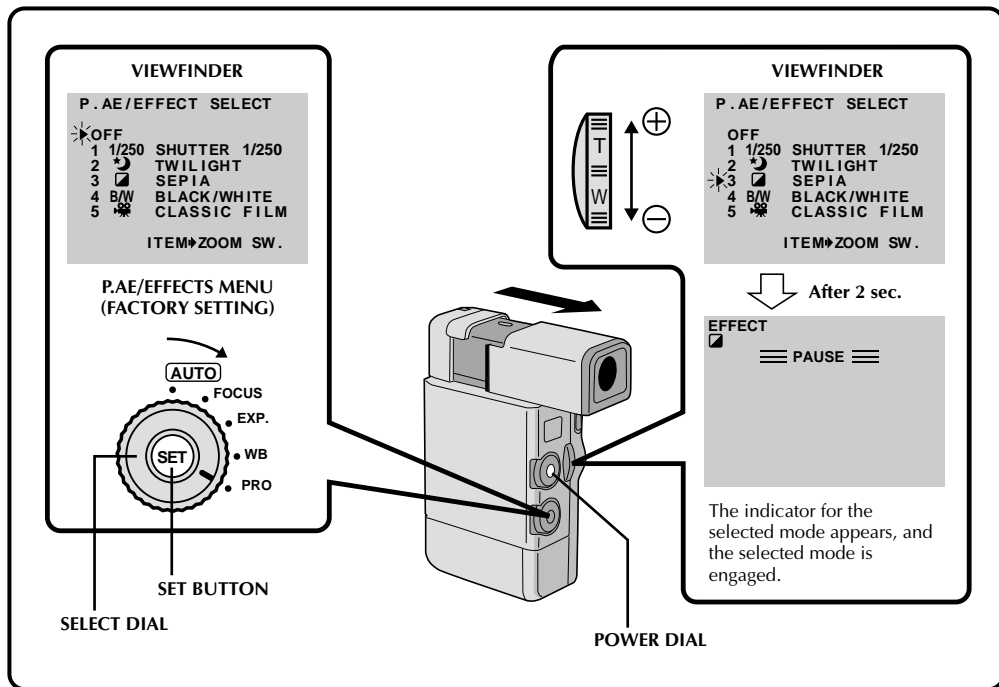

P.AE/Effects

You can choose any one of the effects from the P.AE/Effects Menu. In addition, you can exchange 5 of the 13 options that appear for other available effects (☞ pg. 36).

1 SELECT OPERATION MODE

Set the Select Dial to "PRO". "EFFECT" appears in the viewfinder.

2 ACCESS PRODUCTION EFFECTS MENU

Press **SET** twice. The P.AE/Effects Menu appears in the viewfinder.

3 SELECT EFFECT

Place the pointer next to the desired effect by sliding the Zoom Lever.

- Approximately 2 seconds after you place the pointer, the P.AE/Effects Menu disappears and the selected mode is activated. The name or symbol of the selected mode appears in the viewfinder.

4 DISABLE PRODUCTION EFFECT

To turn off the selected effect, re-access the P.AE/Effects Menu and place the pointer next to "OFF" by sliding the Zoom Lever.

NOTE:

If certain Fades or Wipes are activated, some P.AE/Effects cannot be used. If you select a P.AE/Effect that is unusable in the current situation, the effect's name or symbol begins flashing.

B/W MONOTONE ✓

Like classic black and white films, your footage is shot in B/W. Used together with the Wide Cinema function, it enhances the “classic film” effect.

**SEPIA** ✓

Recorded scenes have a brownish tint like old photos. Combine this with the Cinema mode for a classic look.

**CLASSIC FILM** ✓

Gives recorded scenes a strobe effect.

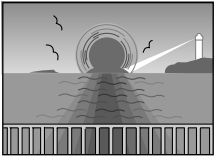
**TWILIGHT** ✓

Makes evening scenes look more natural.

**** Checked “✓” effects are factory preset.**

To use other effects, refer to “Exchanging P.AE/Effects” on page 36.

SLOW (Slow Shutter)

You can light dark subjects or areas even brighter than they would be under good natural lighting.



x 4 = 4 times sensitivity
(shutter speed 1/12.5 sec.)



x 10 = 10 times sensitivity
(shutter speed 1/5 sec.)

NOTES:

- When using *Slow*, the image takes on a strobe-like effect.
- Use *Slow* only in dark areas.
- The Manual Focus indication may appear and flash when *Slow* is in use.
- If the image is out of focus, adjust manually. It is also recommended that you use a tripod, if possible.

**VIDEO ECHO**

Adds a “ghost” to the subject, giving your recording a “fantasy” feeling.

**STROBE**

Your recording looks like a series of consecutive snapshots.

**SHUTTER
(Variable
Shutter
Speed)**

1/50—The shutter speed is fixed at 1/50th of a second.

1/100—The shutter speed is fixed at 1/100th of a second.

1/250 (factory preset), 1/500—These settings allow fast-moving images to be captured one frame at a time, for vivid, stable slow-motion playback. The faster the shutter speed, the darker the picture becomes. Use in areas with good lighting.

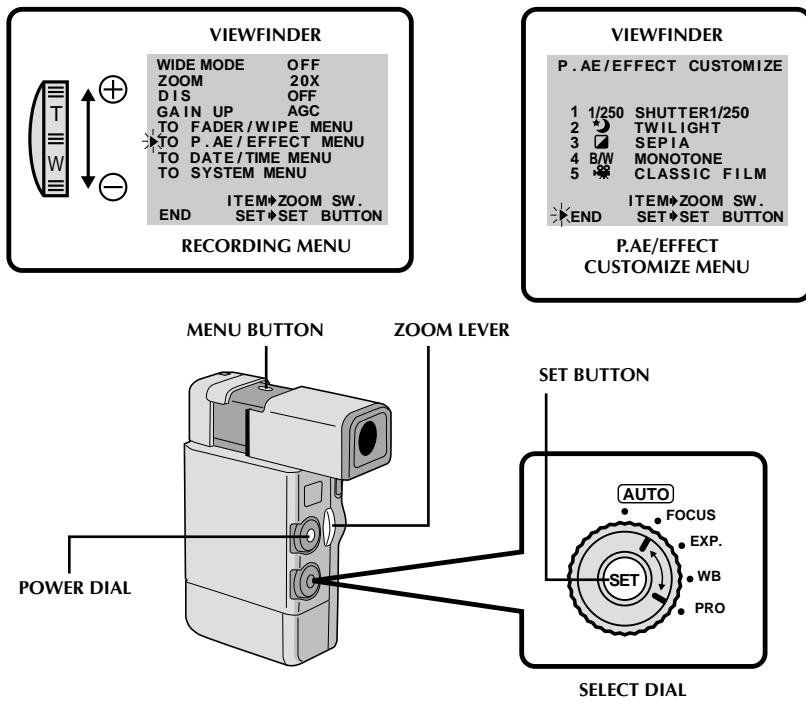

Exchanging P.AE/Effects

You can replace 5 of the effects that appear in the menu with 5 others.

1 SELECT MODE

Set the Select Dial to "PRO".

2 ACCESS RECORDING MENU

Press MENU. The Recording Menu appears in the viewfinder.

3 ACCESS PRODUCTION EFFECTS CUSTOMIZE MENU

Place the pointer next to "TO P.AE/EFFECT MENU" by sliding the Zoom Lever. Then press SET and the P.AE/Effect Customize Menu appears in the viewfinder.

4 SELECT EFFECT TO BE REPLACED

Place the pointer next to the number of the effect you want to replace by sliding the Zoom Lever, then press SET. The pointer stops blinking.

5 SELECT NEW EFFECT

Cycle through the remaining effects by sliding the Zoom Lever in either direction, and stop when the one you want is displayed. Press SET.

- The pointer automatically moves to "END".
- To replace other effects, repeat steps 4 and 5.

6 CLOSE MENU

Press SET twice. Selection is finished, and you can use the new effect(s) in recording (☞ pg. 34).

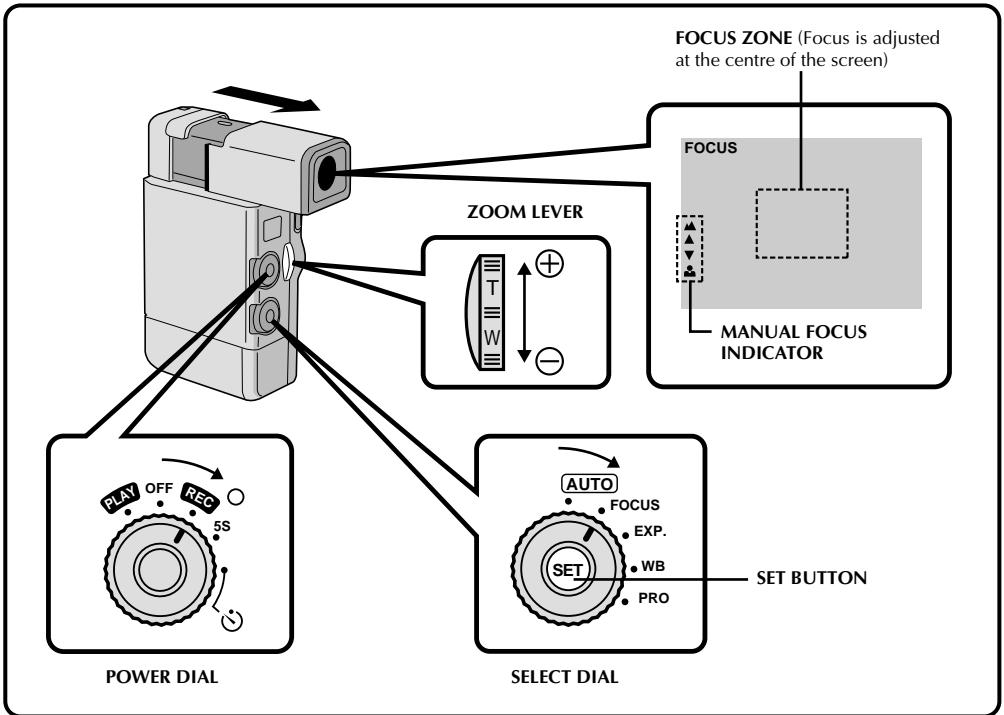

Manual Focus Adjustment

The recorder, in most cases, adjusts the focus from 10 cm to infinity automatically. However, when focusing is difficult or when the subject is not in the middle of the viewfinder, adjust the focus manually.

1 SELECT MODE
Set the Select Dial to "FOCUS". "FOCUS" is displayed in the viewfinder.

2 ACCESS MANUAL FOCUS DISPLAY
Press SET. The Manual Focus display appears in the viewfinder. The focus is locked at this point.

3 ADJUST FOCUS
While holding down SET, slide the Zoom Lever toward "+" to adjust to faraway targets, or toward "-" to focus on closer targets.

- When the focus reaches its near or far limit, the "▲" or "●" will begin blinking.
- When focus cannot be adjusted manually, try zooming in or out, then try the manual focus adjustment again.

To Change To Auto Focus . . .

..... set the Select Dial to "FOCUS" and press SET once quickly. The manual focus indications disappear. Or set the Select Dial to "AUTO".

NOTES:

Manual focus is recommended in the following situations:

- When shooting a flat wall, a blue sky or an object with little or no contrast.
- When wire or other obstacles come between the camcorder and the subject.
- When shooting in dark places.
- When shooting objects with a detailed design or pattern.
- When shooting under fluorescent or flickering lighting.

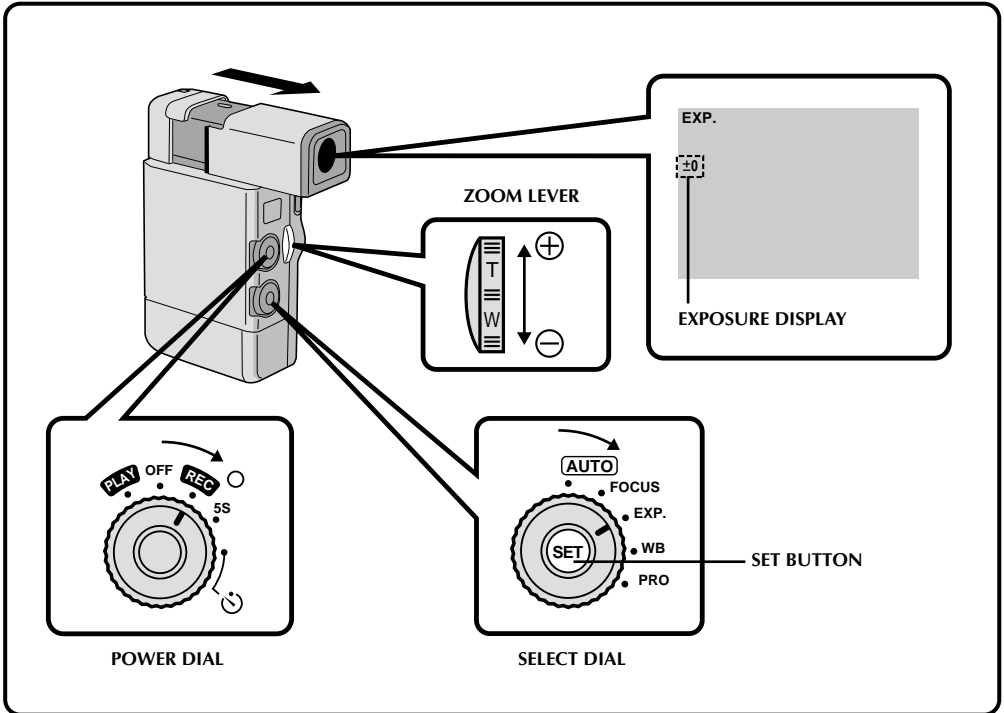

Exposure Control

Usually this is adjusted automatically. However, when the background is too bright or too dark in comparison with the subject, adjust the Exposure manually.

1 SELECT MODE
Set the Select Dial to "EXP". "EXP" is displayed in the viewfinder.

2 ADJUST EXPOSURE
Slide the Zoom Lever while holding down SET. The Exposure Control indicator appears in the Viewfinder.

- The adjustment range is from -6 to +6. Slide toward "+" to brighten the image, or toward "-" to darken it.

To Return To Automatic Exposure Control . . .
..... set the Select Dial to "EXP", then press SET quickly. The Exposure setting display disappears. Or set the Select Dial to "AUTO".

NOTES:

Manual exposure adjustment is recommended in the following situations:

- When shooting using reverse lighting or when the background is too bright.
- When shooting on a reflective natural background such as at the beach or when skiing.
- When the background is overly dark or the subject light.

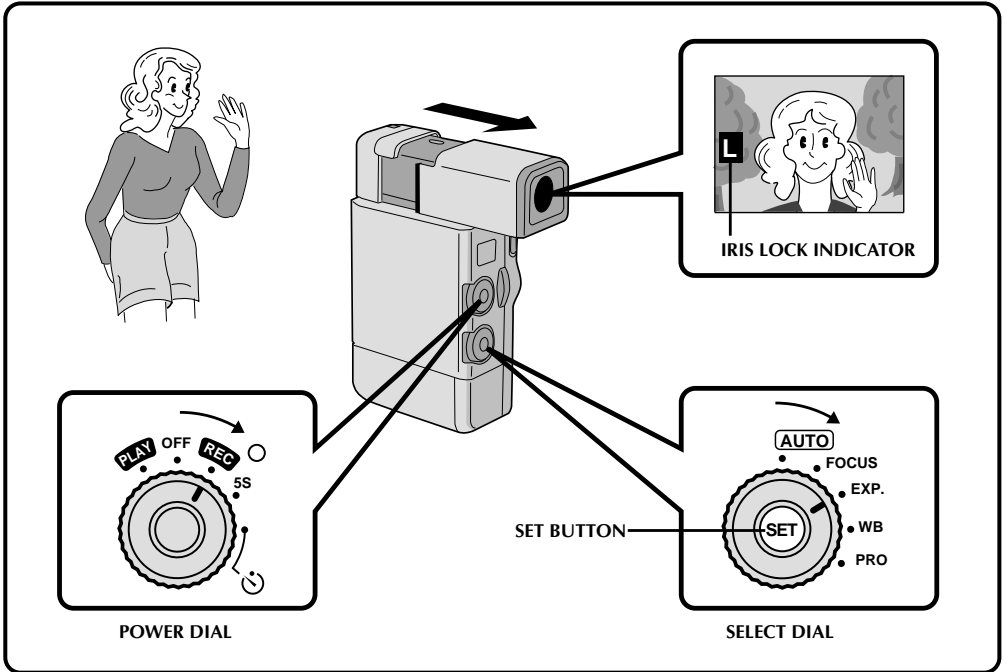

Iris Lock

Use this function when shooting a moving subject, when zooming, when the subject changes its distance (thus its size in the viewfinder), or when you want to lock the brightness level.

When the subject is close, keep the iris locked. Even when the subject moves away from you, the image will not darken.

1 SELECT MODE

Set the Select Dial to "EXP". "EXP." is displayed in the viewfinder.

2 CENTRE SUBJECT, LOCK IRIS

Adjust zoom so that the subject fills the viewfinder, then press and hold **SET** for about 2 seconds. The exposure setting display and "L" appear, indicating that the iris is locked.

To Return To Automatic Iris Control . . .

..... set the Select Dial to "EXP", then press **SET**. The exposure setting display and "L" disappear. Or set the Select Dial to "AUTO".

NOTES:

Iris lock is recommended in the following situations:

- When shooting on a reflective natural background such as at the beach or when skiing.
- When shooting objects under a spotlight.
- When the subject is backing away.
- When zooming.

** Locking the exposure control and the iris

After step 1, adjust the exposure using the Zoom Switch while holding **SET**. Then lock the iris in step 2. For automatic locking, press **SET** quickly. The iris becomes automatic after about 2 seconds.

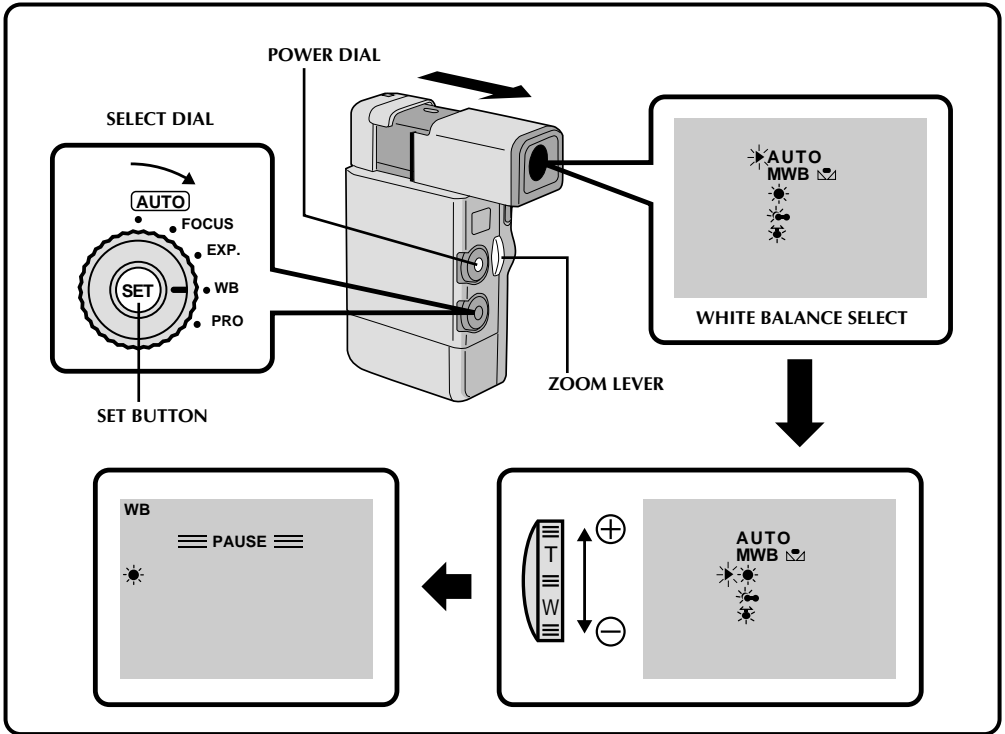

White Balance Adjustment

The white balance is usually adjusted automatically. However, when you want to shoot in various types of lighting, or when shooting a scene with changing tint, use this function.

1 SELECT MODE

Set the Select Dial to "WB". "WB" appears in the viewfinder.

2 ACCESS WHITE BALANCE DISPLAY

Press SET. The White Balance display appears in the viewfinder.

3 ADJUST WHITE BALANCE

Slide the Zoom Lever in the appropriate direction while watching in the viewfinder.

AUTO—The white balance is adjusted automatically. This is the factory preset position.

MWB ☁️—When shooting with the white balance already having been set on the subject (☞ pg. 41).

☀️—When shooting outdoors on a sunny day.

☁️—When shooting outdoors on a cloudy day.

💡—When using a video light or other similar type of lighting.

4 ENTER SELECTION

Press SET. Setting is complete and the indicator representing the selected setting appears in the viewfinder.

To Return To Automatic White Balance . . .

..... select "AUTO" in step 3. Or set the Select Dial to "AUTO".

NOTES:

- White balance cannot be used when P,AE/Effects Sepia or Monotone are activated.
- Confirm the tint setting on a TV before connecting, to make sure the displays are as close as possible.

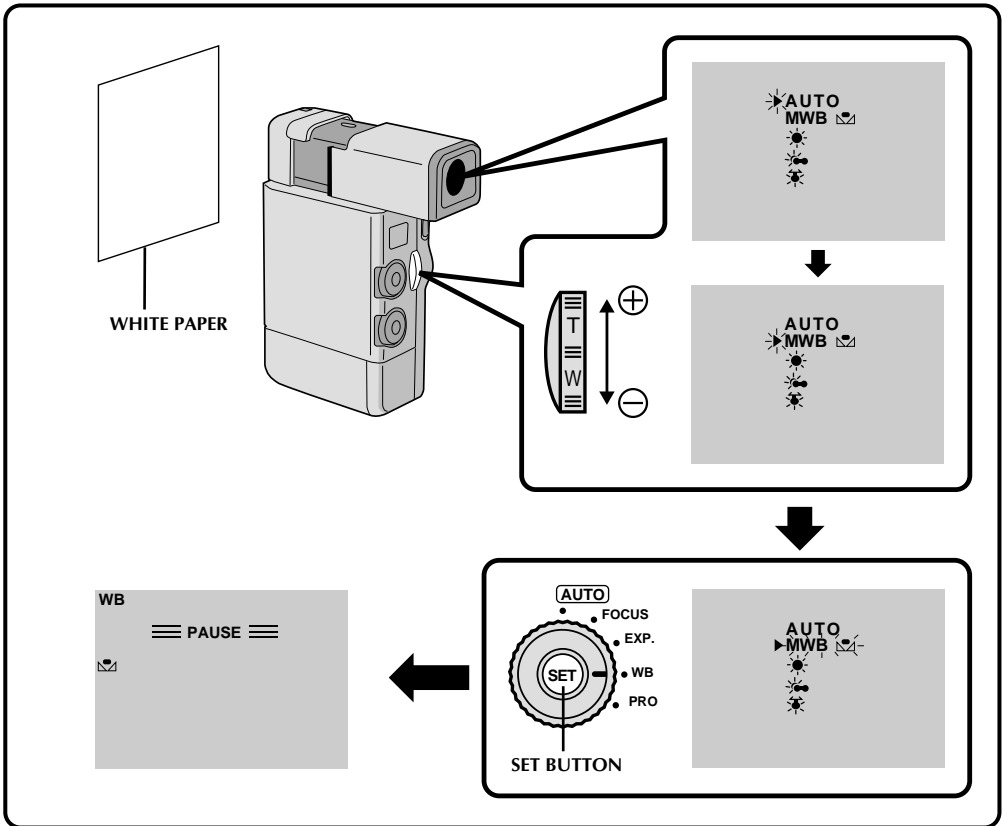

MWB Operation

Set this function before shooting subjects under various types of lighting.

- 1 SELECT MODE**
In step 3 of the White Balance adjustment (pg. 40), select "MWB".
- 2 SET MWB**
Hold a sheet of plain white paper in front of the subject. Adjust zoom or position yourself so that the white paper fills the screen.
- 3 ENTER SETTING**
Press and hold SET. When the MWB indicator begins blinking, release the button. The camcorder exits the menu and setting is complete.
The MWB indicator appears in the viewfinder.

To Change The Tint For Recording . . .

.... In step 2, substitute coloured paper for white. The white balance is adjusted based on the colour, changing the tint. Red paper — deeper green; blue paper — orange; yellow paper — deeper purple.

NOTES:

- A subject can be shot under various types of lighting conditions indoors (natural, fluorescent, candlelight, etc.). Because the colour temperature is different depending on the light source, the tint of the subject will differ depending on the white balance settings. Use this function for a more natural result.
- Once you adjust white balance during MWB operation, the setting is retained even if the power is turned off or the battery removed.

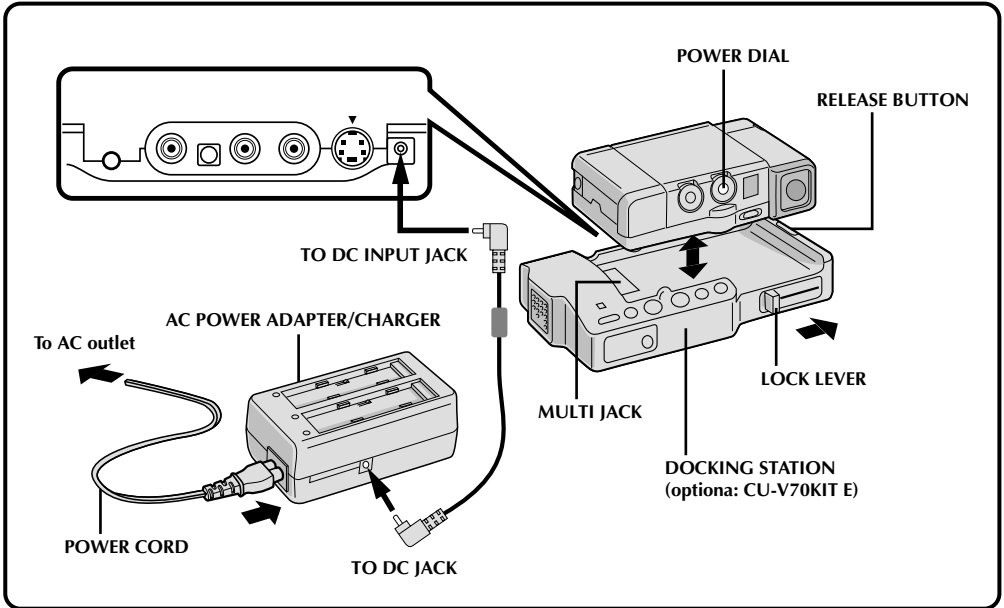

Docking Station (optional: CU-V70KIT E) Attachment

When you attach your camcorder to the Docking Station, you can add many interesting effects during playback.

1 CONFIRM POWER-OFF STATUS

Make sure the camcorder's power is off.

2 PLACE CAMCORDER IN DOCKING STATION

If you plan to use the MENU button while the camcorder is docked, you need to pull out its viewfinder before attaching.

3 ATTACH AND LOCKS

Press down on the camcorder and slide the Lock Lever in the direction of the arrow. The camcorder and the Docking Station are now securely attached.

- Make sure that the camcorder does not have a DC cord or an AV cable connected to it before attaching.
- When removing the camcorder, press the Release button and lift the camera out.

4 SUPPLY POWER



Connect the AC Adapter between the Docking Station and an AC outlet.

- The Docking Station cannot function using the camcorder's battery.

5 SELECT MODE

Set the Power Dial to "PLAY".

Using The Remote Control During Playback

Once the camcorder is attached to the Docking Station, you can use the RM-V708U or RM-V710U remote control for regular playback, slow motion (approx. 1/10 speed— pg. 48), Playback Zoom ( pg. 48), and P.AE/Effects ( pg. 34).

Charging The Camcorder Battery

If you attach the camcorder with the battery installed to the Docking Station, you can charge the battery. Set the Power Dial to "OFF", then perform steps 1 through 4 of the Docking Station Attachment procedure. The Docking Station's charging lamp starts blinking to indicate that charging has begun. When it stops blinking but stays on, charging is complete.

CHARGING TIME

BATT. PACK	CHARGE
BN-V712U	approx. 170 min.
BN-V714U	approx. 180 min.

- Do not attach or remove the battery while the camcorder is attached to the Docking Station.

TV Playback

* Please refer to your VCR and/or TV instruction manual(s) when connecting.

NOTE:

During playback, if the camcorder is left on its side for an extended period, its surface will become very warm. It is recommended that you use the Docking Station (☞ pg. 42) or the CAM Stand (☞ pg. 10) during playback.

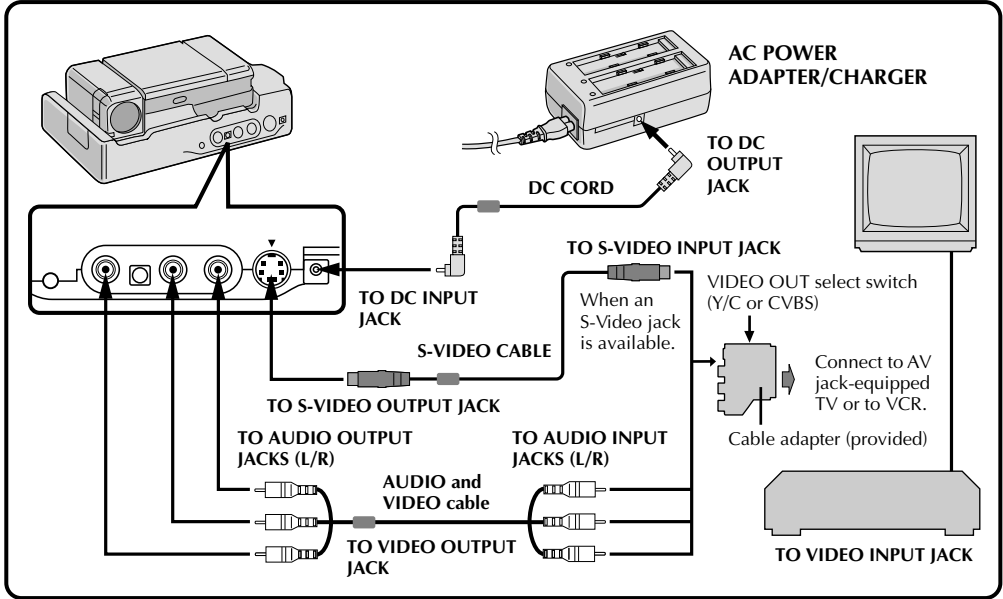

1 CONNECT DOCKING STATION TO TV OR VCR

Connect as shown in the illustration. If your TV/VCR has the SCART connector, use the provided cable adapter.

2 TURN ON POWER

Turn on the power to the camcorder and the TV/VCR.

3 SELECT TV'S VIDEO MODE

Set the TV to the channel or mode appropriate for video playback.

If Using A VCR . . . go to step 4.
If not . . . go to step 5.

4 CONNECT VCR OUTPUT TO TV INPUT

Refer to your VCR's instruction manual.

5 START PLAYBACK

Press **PLAY**. You can watch the scenes you recorded on the TV.

6 END PLAYBACK

Press **STOP** and, if you're not going to continue using the camcorder, set the Power Dial to "OFF".

NOTES:

- If, when using an S-Video cable, there's no picture, connect the camcorder's output to the regular video input on the TV or VCR and try again.
- Set the VIDEO OUT select switch of connector as required: either to "CVBS" (with the direct VCR connection) or to "Y/C" (with the RGB converter connection).

VCR/TV Connection

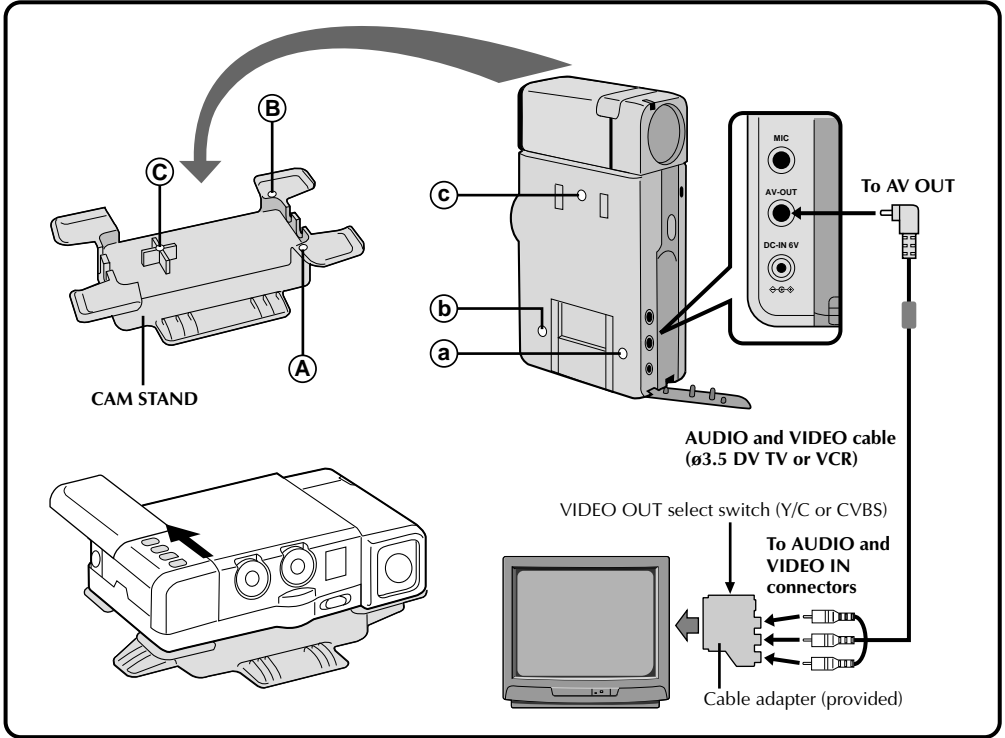
**1 CONNECT CAMCORDER TO TV OR VCR**

Connect as shown in the illustration. If your TV/VCR has the SCART connector, use the provided cable adapter.

2 ATTACH CAM STAND TO CAMCORDER

Line up **A** with **a**, **B** with **b** and **C** with **c**. The CAM Stand has two sides. One side is used to hold the camcorder upright and the other side is used to hold the camcorder flat.

3 TURN ON POWER

Turn on the power to the camcorder and the TV/VCR.

4 SELECT TV'S VIDEO MODE

Set the TV to the channel or mode appropriate for video playback.

*If Using A VCR . . . go to step 5.
If not . . . go to step 6.*

5 CONNECT VCR OUTPUT TO TV INPUT

Refer to your VCR's instruction manual.

6 START PLAYBACK

Slide the cover (☞ pg. 45) and press **PLAY**. You can watch the scenes you recorded on the TV.

7 END PLAYBACK

Press **STOP** and, if you're not going to continue using the camcorder, set the Power pDial to "OFF".

NOTES:

To choose whether or not the following displays appear on the connected TV . . .

- **Date/Time, Time Code**
..... set to "ON" or "OFF" in the Playback Menu (☞ pg. 49).
- **Playback Sound Mode Display**
..... set the Power Dial to "REC", and set "ON SCREEN" in the Date/Time Menu (☞ pg. 12) to "ON" or "OFF". Then set the Power Dial back to "PLAY".
- Set the **VIDEO OUT** select switch of connector as required: either to "CVBS" (with the direct VCR connection) or "YC" (with the RGB converter connection).

You can watch what you've recorded in the viewfinder.

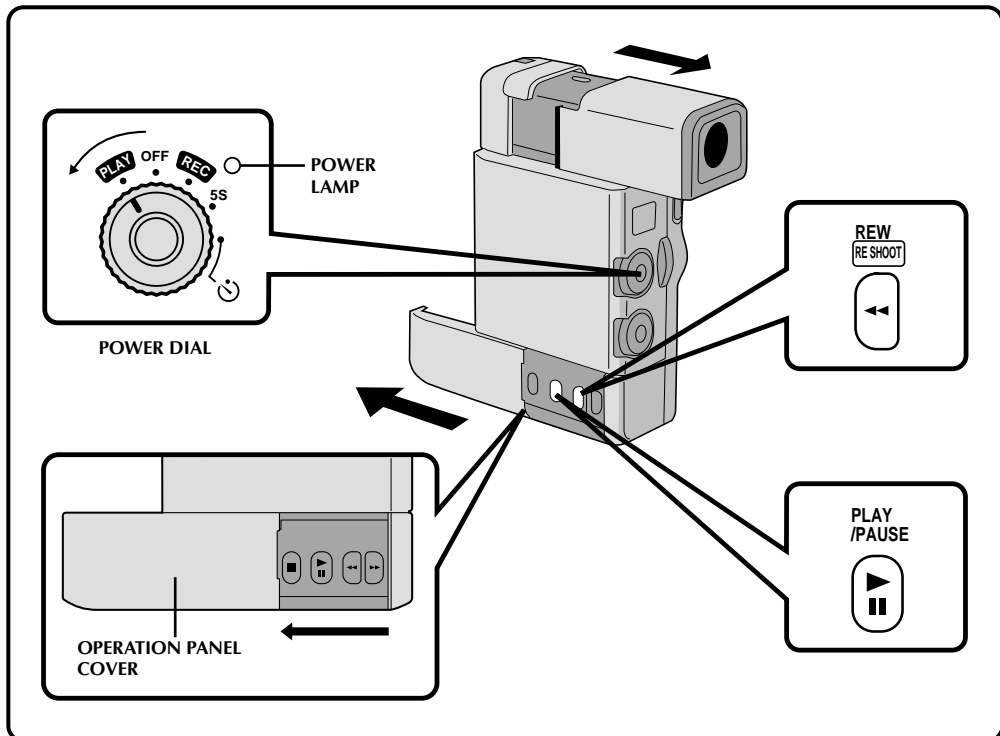

- 1 SELECT MODE**
Pull out the viewfinder and set the Power Dial to "PLAY".
- 2 OPEN COVER**
Slide the camcorder's Operation Panel cover as shown in the illustration.
- 3 REWIND TAPE**
Press **REW**. If you rewind all the way to the end of the tape, it stops automatically.
- 4 WATCH RECORDING**
Press **PLAY**. You can watch the recording in the viewfinder.
- 5 END PLAYBACK**
Press **STOP** and set the Power Dial to "OFF".

NOTES:

- You can also perform a High-Speed Search by pressing and holding **REW** or **FF** during the **PLAY** mode. The search continues as long as you hold the button. Once you release it, normal playback resumes.
- A slight mosaic effect appears on screen during High-Speed Search. This is not a malfunction.
- The sound is not available during High-Speed Search.

Still Playback

To temporarily stop playback, press **PAUSE**. Press again to resume playback. If still playback continues for more than about 3 minutes, the camcorder's Stop mode is automatically engaged. After 5 minutes in the stop mode, the camcorder's power is automatically turned off.

To Perform High-Speed Search . . .

..... press **REW** or **FF** after pressing **PLAY**. The tape will move at approximately 9 times the normal playback speed. Watch in the viewfinder and, when you reach the spot you want to see, press **PLAY** and normal playback resumes.

Playback Menu

The Playback Menu allows you to set the following functions: *Playback Sound (48 kHz, 32 kHz), Synchro Comp, Display and Time Code*. The following procedure applies to all except *Synchro Comp* (☞ pgs. 55–56).

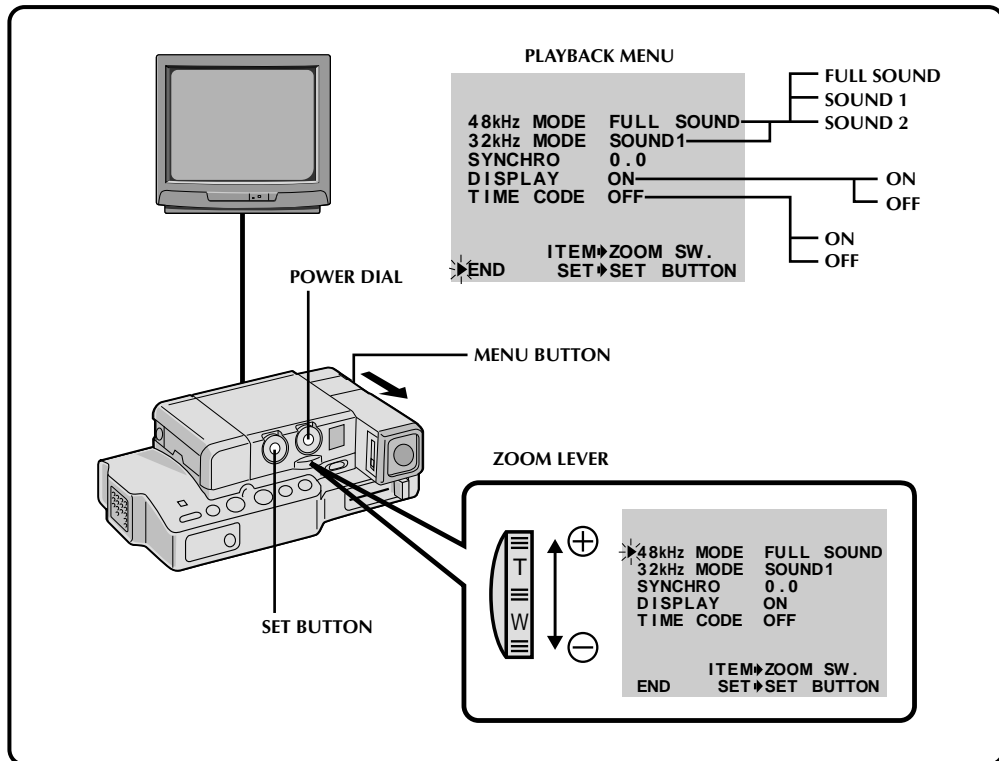

1 ACCESS PLAYBACK MENU

Press **MENU**. The Playback Menu appears in the viewfinder and on the connected TV.

2 SELECT FUNCTION

Place the pointer next to the desired function by sliding the Zoom Lever, then press **SET**. The pointer stops blinking, indicating that the function has been selected.

3 SET FUNCTION PARAMETERS

Slide the Zoom Lever to cycle through the available settings for the selected function, and stop when the desired setting appears. Then press **SET**, and the pointer automatically moves to "END".

- To set parameters for other functions, repeat steps 2 and 3.

4 CLOSE MENU

Press **SET** again, and the menu disappears.

Playback Sound

During playback, the camcorder detects the sound mode in which the recording was made, and plays the sound back. Select the type of sound to accompany your playback picture. (48 kHz is preset to "FULL SOUND" and 32 kHz is preset to "SOUND 1".)

RECORDING SOUND	DISPLAY	OUTPUT SOUND
48 kHz	FULL SOUND	Stereo sound
	SOUND 1	"L" sound is output on both channels
	SOUND 2	"R" sound is output on both channels
32 kHz	FULL SOUND	Stereo sound
	SOUND 1	
	SOUND 2	

When watching a tape recorded at 48 kHz, if you want to change the output sound, access the Playback Menu and, in step 3 on page 46, select "48kHz MODE" and set it for "FULL SOUND", "SOUND 1" or "SOUND 2". When playing back a tape recorded at 32kHz, set in the same manner. For information on output sound during Audio Dubbing, see page 57.

NOTES:

- You can also use the RM-V708U or RM-V710U remote control's **AUDIO MONITOR** Button to change the output sound (without having to access the Playback Menu). Make sure you point the remote control at the Docking Station's sensor.
- During playback, the camcorder detects the sound mode in which the recording was made. This detection cannot be made during fast-forward or rewind.

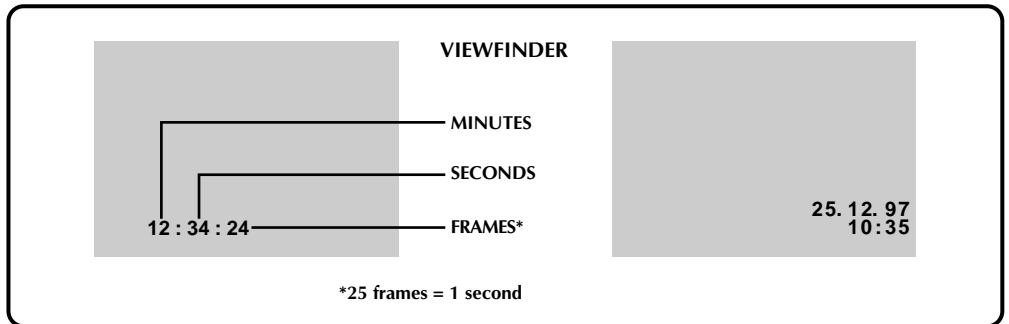

Displaying The Time Code During Playback

You can display the Time Code on screen during playback. This is especially useful for editing. This function is preset to "OFF". To turn it on, select "TIME CODE" at the Playback Menu and change the setting.

ON– The Time Code is displayed on the playback screen.

OFF–The Time Code doesn't appear.

Displaying the Date During Playback

If the time has been set, the date is automatically recorded separately from the recorded video signal. You can display or remove the date anytime during playback. This function is preset to "ON". To turn it off, select "DISPLAY" at the Playback Menu and change the setting.

ON– The date is displayed on the playback screen.

OFF–The date is not displayed, or is removed.

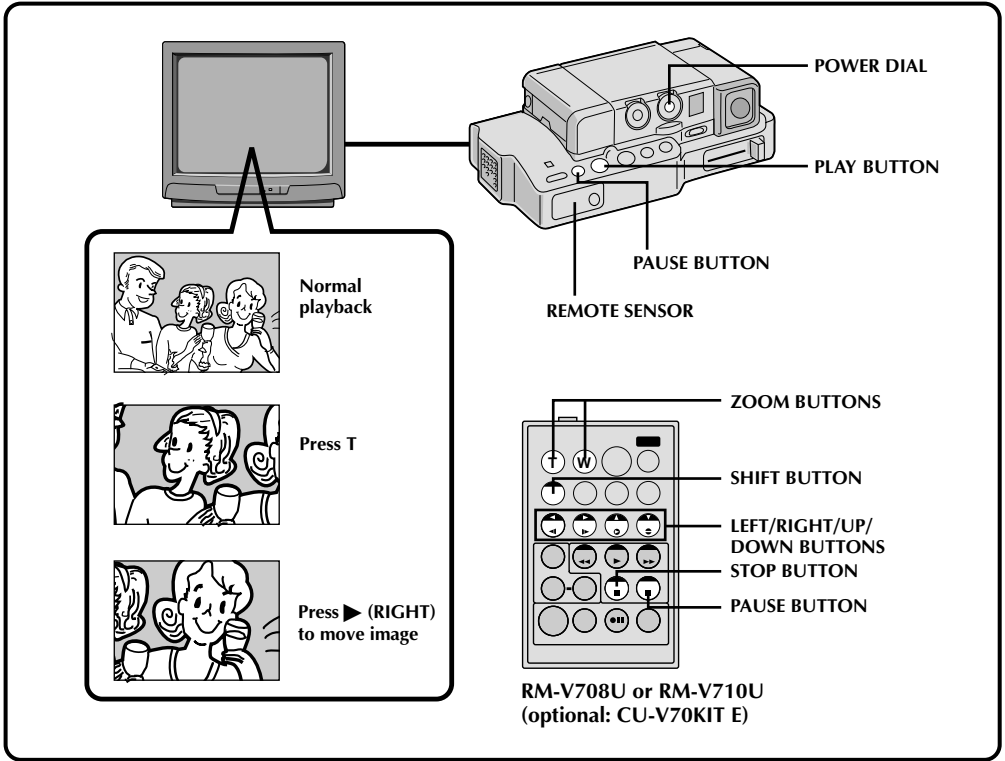

Playback Zoom

The recorded pictures can be magnified up to 10x at any time during playback.

1 FIND 'ZOOM' SCENE

Press **PLAY** to start playback.

2 ACTIVATE ZOOM

Press **ZOOM** on the remote control. Make sure the remote control is pointed at the Docking Station's sensor.

- Pressing **T** zooms in.

3 LOCATE PORTION OF MAGNIFIED SCENE

You can move the image on screen around to find a particular portion of the picture. While holding down **SHIFT**, press **◀ (LEFT)**, **▶ (RIGHT)**, **▲ (UP)** and **▼ (DOWN)**.

4 END ZOOM

Press and hold **W** until magnification returns to normal. Or, press **STOP** and then press **PLAY**.

NOTES:

- Zoom can also be used during slow-motion and normal playback.
- If the Video Echo effect (pg. 49) is selected during playback zoom, playback zoom is canceled.

Slow-motion Playback:

Slow-motion Playback is available using the Remote control unit and Docking Station which are included in the accessory kit CU-V70KIT E (optionally available).

- To change from normal to slow-motion playback, press **PAUSE**, then point the remote control at the Docking Station and press **SLOW**. After playing back in slow motion for about 20 seconds, normal playback resumes. To stop slow-motion playback in progress, press **PLAY**.
- During slow-motion playback, due to digital image processing, the picture may take on a mosaic effect.

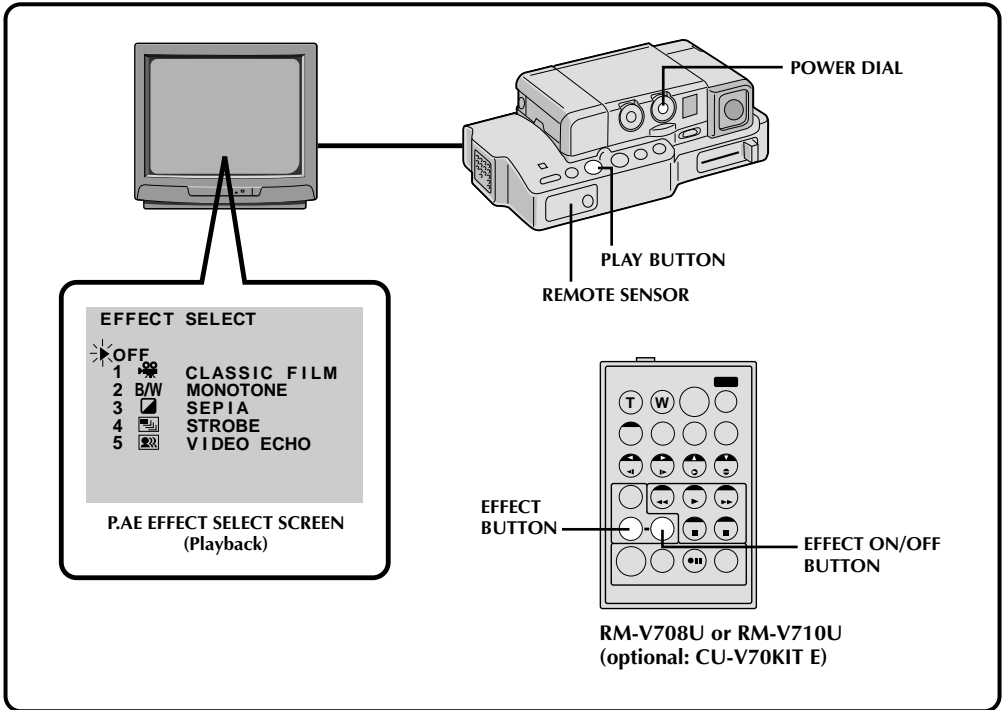

Playback Effects

These effects allow you to be creative with the playback picture. You can use any one of the 5 effects.

1 START PLAYBACK

Press **PLAY**.

2 ACCESS PRODUCTION EFFECTS MENU

Point the remote control at the Docking Station's sensor and press **EFFECT**. The Production Effects Menu appears on the connected TV.

3 SELECT EFFECT

Place the pointer next to the desired effect by pressing **EFFECT**. After 2 seconds the menu disappears and the selected function is activated.

NOTE:

To deactivate the selected effect, press **EFFECT ON/OFF** on the remote control.

The effects that can be used during playback are *Classic Film*, *Monotone*, *Sepia*, *Strobe* and *Video Echo*. The effects work the same in playback as they did in recording. Refer to page 35 for more information.

Docking Station (optional available accessory kit CU-V70KIT E)

Refer to “Docking Station Attachment” on pages 42 and 43 for attachment procedures. Make sure the camcorder is attached to the Docking Station before beginning editing.

Dubbing

You can copy recorded scenes from the camcorder onto a videotape. Refer to your VCR’s instruction manual for details.

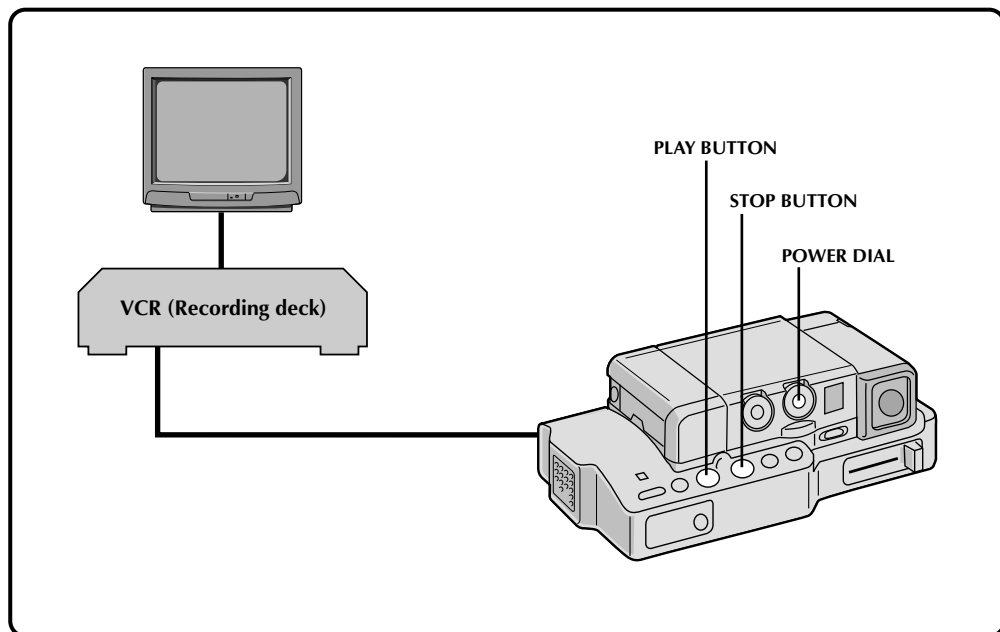

1 MAKE CONNECTIONS

Connect the Docking Station to your VCR as shown in the illustration on page 43.

2 START PLAYBACK

Press **PLAY** to play back the source tape.

3 START RECORDING

While watching on the connected TV, engage your VCR’s record mode from the spot on the source tape you want to begin recording.

4 PAUSE RECORDING

Engage your VCR’s pause mode to stop recording a segment.

5 END RECORDING

Press **STOP** to stop the source tape, and engage the VCR’s stop mode.

NOTES:

- You can use Playback Zoom (☞ pg. 48) or Playback P.AE/Effects (☞ pg. 34) in step 2.
- Before you start dubbing, make sure that the viewfinder indications don’t appear on the connected TV. If they do appear during dubbing, they are being recorded onto the new tape. To clear the Playback Sound Mode Display, press **DISPLAY** on the RM-V708U or RM-V710U Remote Control.
- Select “DISPLAY” and “TIME CODE” from the Playback Menu to show or hide the Date/Time and the Time Code on the recording.

Brand Setting

Before you can perform Automatic Dubbing, or control the VCR using the RM-V708U or RM-V710U remote control, you must set the VCR brand.

SET REMOTE/VCR CODE

1 SET REMOTE TO OPERATE VCR

Turn off the power to the VCR and point the remote toward the VCR's infrared sensor. Then, referring to the VCR CODE LIST on the left, press and hold **MBR SET**, and press button (A) and then (B).

- The code is automatically set once you release the **MBR SET** button, and the VCR's power comes on.

2 OPERATE THE VCR

Make sure the VCR's power is on. Then, while holding **SHIFT**, press the button on the remote for the desired function. The functions the remote can control are PLAY, STOP, PAUSE, FF, REW and VCR REC STBY (you don't need to press **SHIFT** for this one).

You're now ready to try Random Assemble Editing.

IMPORTANT

Although the MBR is compatible with JVC VCRs and those of many other makers, it may not work with yours or may offer limited functions.

NOTES:

- If the VCR's power doesn't come on in step 1, try another code from the VCR CODE LIST.
- Some brands of VCR don't come on automatically. In this case, turn the power on manually and try step 2.
- If the RM-V708U or RM-V710U is not able to control the VCR, use the controls on the VCR.

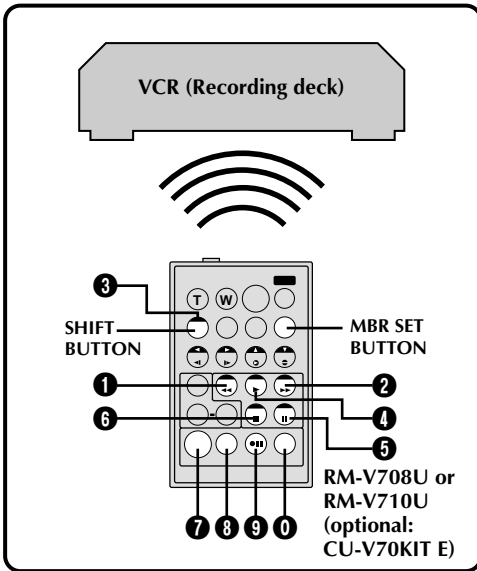

VCR CODE LIST

VCR BRAND NAME	BUTTONS (A) (B)	VCR BRAND NAME	BUTTONS (A) (B)
AKAI	6 2 6 4 7 7	PHILIPS	1 9 9 5 1 1 9 4 9 1 9 6 1 2 3 3
BLAUPUNKT	1 3	SANYO	3 6 3 5
FERGUSON	9 7 9 8 3 2	SELECO, REX	9 1 9 6
GRUNDIG	1 4 3 4	SHARP	1 5 1 0
HITACHI	6 6 6 3	SONY	6 5 6 0 3 9 3 1
JVC A B C	9 1 9 6 9 3	THOMSON, TELEFUNKEN, SABA, NORDMENDE	9 1 9 6 9 7 3 2
MITSUBISHI	6 7 6 8	TOSHIBA	6 9 6 1
NEC	3 7 3 8		
PANASONIC	1 3 1 7 1 1 9 4 1 8		

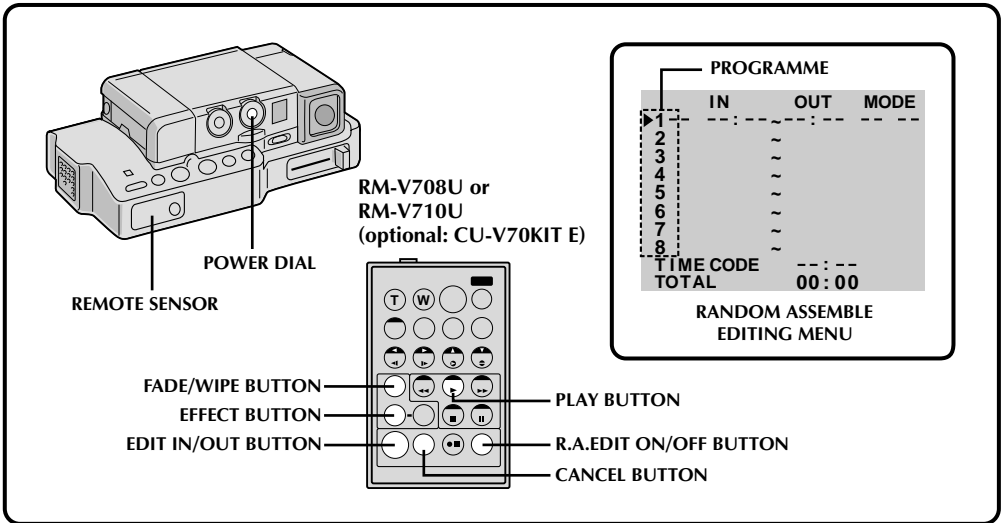

4 SET EDIT-IN POINT

At the beginning of the scene, press **EDIT IN/OUT** on the remote control. The Edit In position appears in the viewfinder and on the connected TV.

5 SET EDIT-OUT POINT

At the end of the scene, press **EDIT IN/OUT**. The Edit Out position appears in the viewfinder and on the connected TV.

6 USE FADE WIPE ON SCENE TRANSITION

Press **FADE/WIPE**.

- Cycle through the effects by pressing repeatedly, and stop when the one you want is displayed.
- If you select a Fade/Wipe effect for an Edit-Out point, the effect is automatically applied to the following Edit-In point.
- When you use Fade/Wipe effects, that time is included in the total time (this does not apply to Picture Wipe/Dissolve).

7 USE P.AE/EFFECT

Press **EFFECT**.

- Cycle through the effects by pressing repeatedly, and stop when the one you want is displayed.
- You can use Classic Film, Monotone, Sepia, Strobe or Video Echo effects.

8 CONTINUE EDITING

Repeat steps 4 – 7.

- If you're not using Fade/Wipe or P.AE/Effects, repeat steps 4 and 5 only.

NOTES:

- When choosing a scene, set Edit-In and Edit-Out points so there's a relatively large difference between them.
- If the search time for an in-point exceeds 5 minutes, the recording deck's Record-Standby mode will be cancelled and editing will not take place.
- If there are blank portions before or after the Edit-In and Edit-Out points, a blue-backed screen may be included in the edited version.
- Since time codes register time only as accurately as seconds, the time code total time may not match the total program time exactly.
- Turning off the camcorder's power erases all registered Edit-In and Edit-Out points.
- To use a P. AE/Effect, press **EFFECT** on the remote control repeatedly to cycle through the effects until the one you want is displayed.
- To change previously registered points, press **CANCEL** on the remote control. The registered points disappear, one at a time, from the most recently registered point.
- If you use Sepia or Monotone P.AE/Effects, you can't use the Dissolve or Black & White Fader. In this case the Dissolve or Black & White indicator begins blinking. Once the next Edit-In point is registered, the effect is turned off. To combine these effects, use Sepia or Monotone during recording, then use Dissolve or Black & White Fader during Random Assemble Editing.

CONTINUED ON NEXT PAGE

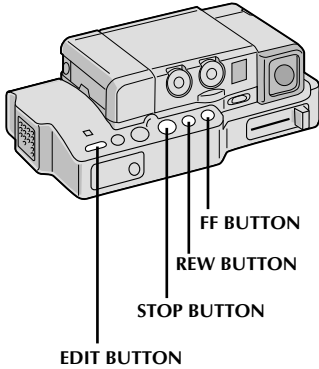

	IN	OUT	MODE
1	W 00:25~02:05	P	
2	P 07:18~08:31	--	
3	-- 03:33~05:53		B/W
4	09:30~13:15		
▶5	15:55~--:--	--	--
6	~		
7	~		
8	~		
TIME CODE		15:55	
TOTAL		09:02	

R.A.EDIT PROGRAMME SCREEN

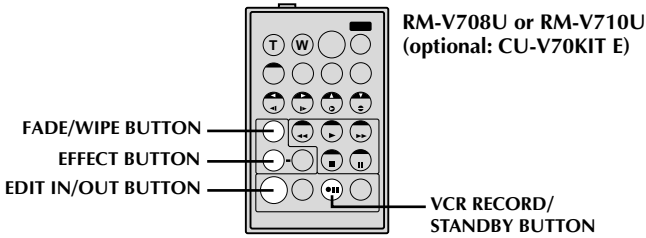

9 PREPARE SOURCE TAPE

Rewind the tape in the camcorder to the beginning of the scene you want to edit and press **PAUSE**.

10 ENGAGE VCR'S RECORD-PAUSE MODE

Point the remote control toward the VCR's infrared sensor and press **VCR RECORD/STANDBY**, or manually engage the VCR's Record-Pause mode.

11 START EDITING

Press **EDIT** on the Docking Station. Editing proceeds as programmed, right through to the end of the last registered scene.

- If you selected a Fade/Wipe effect, it is active between selected scenes during dubbing.
- If you selected a P.AE/Effect, it is active during scenes while dubbing.
- When dubbing is complete, the camcorder enters the PAUSE mode, and the recorder enters its RECORD/STANDBY mode.
- If you don't register an Edit-Out point, the tape will be dubbed all the way to the end automatically.

12 STOP EDITING

Engage the **STOP** modes for the camcorder and the recorder.

NOTES:

- During dubbing, make sure the remote control is pointed at the recorder's sensor, and that the path between the two is unobstructed.
- If, during dubbing, you press a button on the camcorder, its RECORD/STANDBY mode is automatically engaged.
- Random Assemble Editing may not function properly when using a tape including several duplicated Time Codes. (pg. 27)
- When using MOSAIC FADER, black bars may appear at the bottom and left of the screen.

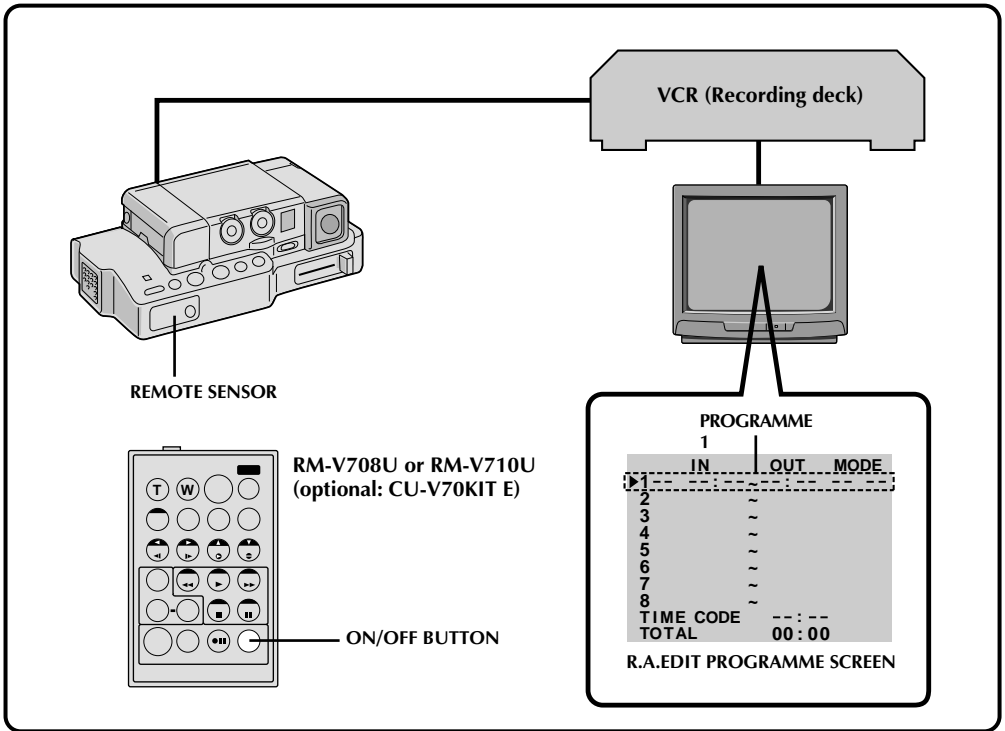

For More Accurate Editing

Some VCRs make the transition from RECORD/STANDBY to RECORD mode faster than others. Even if you begin editing for the camcorder and the VCR at exactly the same time, you may lose scenes you wanted, or find that you've recorded scenes you didn't want. For a cleanly edited tape, confirm and adjust the timing of the camcorder against your VCR.

1 PREPARE FOR R.A. EDIT

Play back the tape in the camcorder, then point the remote control at the Docking Station's Remote sensor and press **R.A. EDIT ON/OFF**.

- "R.A. EDIT" appears on the TV screen.

2 CHOOSE A SCENE

Perform Random Assemble Editing on PROGRAMME 1 only. In order to check VCR and camcorder timing, select the beginning of a scene transition as your Edit-In point.

3 PLAY BACK DUBBED SCENE

- If any images from the scene prior to the transition you chose for your Edit-In point were recorded, that means your VCR moves quickly from RECORD/STANDBY to RECORD.
- If the scene you tried to dub starts in progress, the VCR is slow to start recording.

CONTINUED ON NEXT PAGE

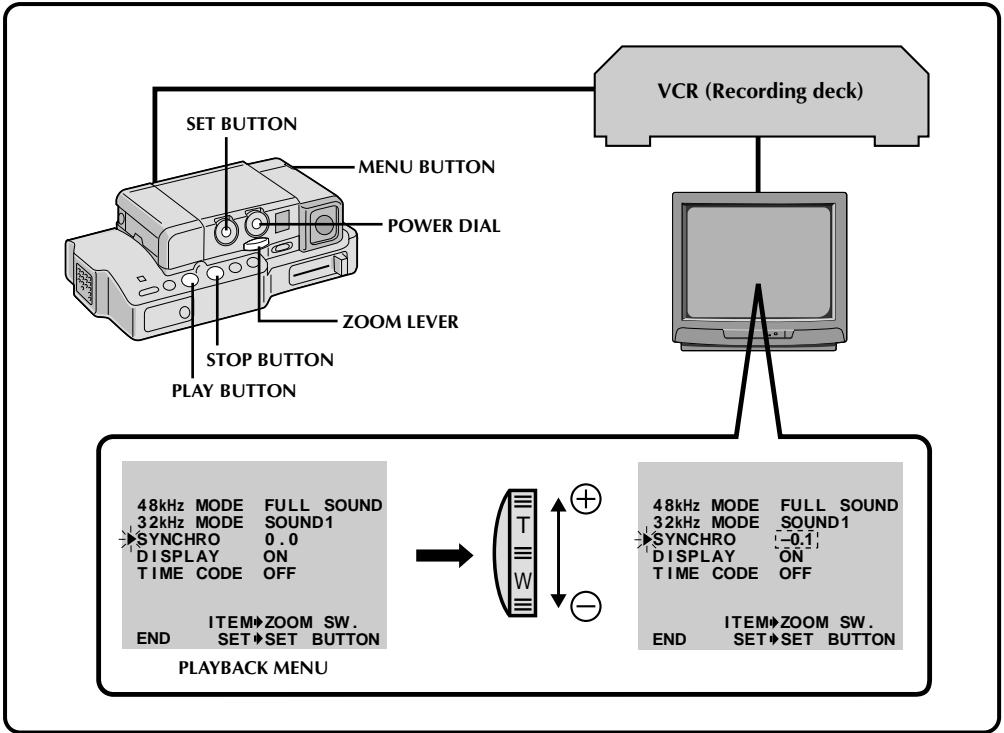

4 SELECT OPERATION MODE
Set the Power Dial to "PLAY" and press **PLAY**.

5 ACCESS PLAYBACK MENU
Press **MENU**. The Playback Menu appears on the TV screen.

6 SELECT FUNCTION
Place the pointer next to "SYNCHRO" by sliding the Zoom Lever, then press **SET**. The pointer stops blinking, indicating that the function has been selected.

7 INPUT CORRECTION DATA
If the VCR is quick, slide the Zoom Lever toward "-"; if the VCR is slow, slide toward "+". The adjustment range is from -1.3 to +1.3 seconds, in 0.1-second increments.

8 CLOSE MENU
Press **SET** twice.

- Now perform Random Assemble Editing beginning with step 2 on page 52.

NOTE:

Depending on the recorder, there may be situations where the timing difference cannot be fully corrected.

Audio Dubbing

Using a tape recorded at 32 kHz, you can customize the soundtrack of a tape you've recorded.

NOTE:

Audio Dubbing is not possible on a tape recorded at 48 kHz.

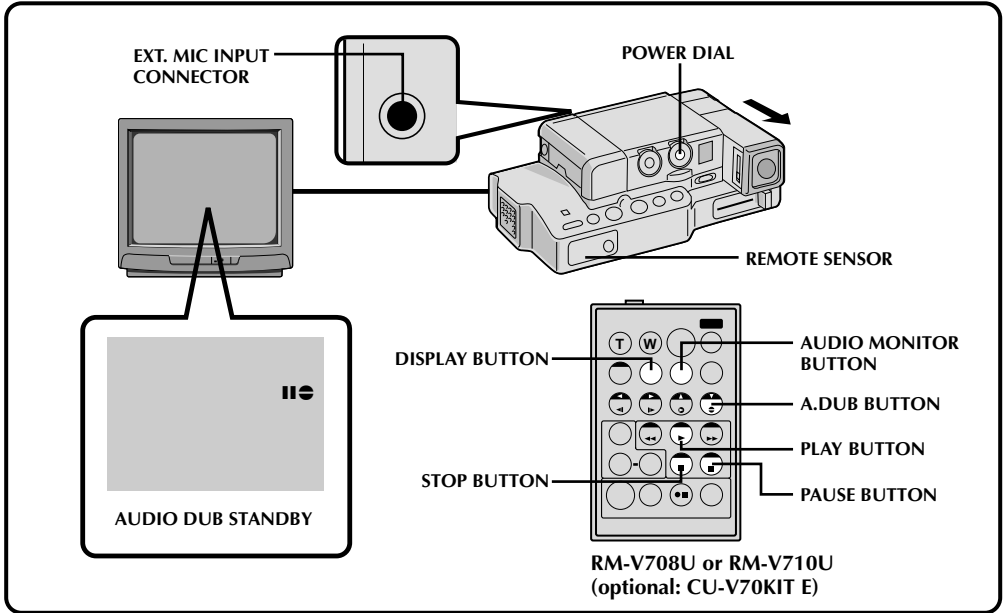

1 FIND EDIT-IN POINT

Play back the tape to locate the point where editing will start, then press **PAUSE**.

2 CONNECT EXTERNAL MICROPHONE

Connect an optional stereo microphone. Then while holding **A. DUB** on the remote control, press **PAUSE**.

- Pull out the viewfinder and "II" appears.
- Press **DISPLAY** on the remote control if sending the image to a connected TV.

3 BEGIN DUBBING

Press **PLAY**, then begin "narrating" using the external microphone.

4 PAUSE DURING DUBBING

Press **PAUSE**.

5 STOP DUBBING

Press **STOP**.

NOTES:

- When editing onto a tape that was recorded at 32 kHz, the old and new soundtracks are recorded separately.
- To select the desired sound for playback, press **AUDIO MONITOR** on the remote control.
- If you dub onto a blank space on the tape, the sound may be disrupted. Make sure you only edit recorded areas.
- If feedback or howling occurs, move the Docking Station so the camcorder's microphone is away from the TV, or turn down the TV's volume.
- If you change from 32 kHz to 48 kHz in mid-recording and then use the tape for Audio Dubbing, it is not effective from the point where 48 kHz recording began.

RECORDING SOUND	DISPLAY	OUTPUT SOUND
32 kHz	FULL SOUND	Original and new tracks are combined and output in stereo.
	SOUND 1	Original track is output on both "L" and "R" channels in stereo.
	SOUND 2	New track is output on both "L" and "R" channels in stereo.

Insert Editing

You can insert snapshots and other scenes in previously recorded footage.

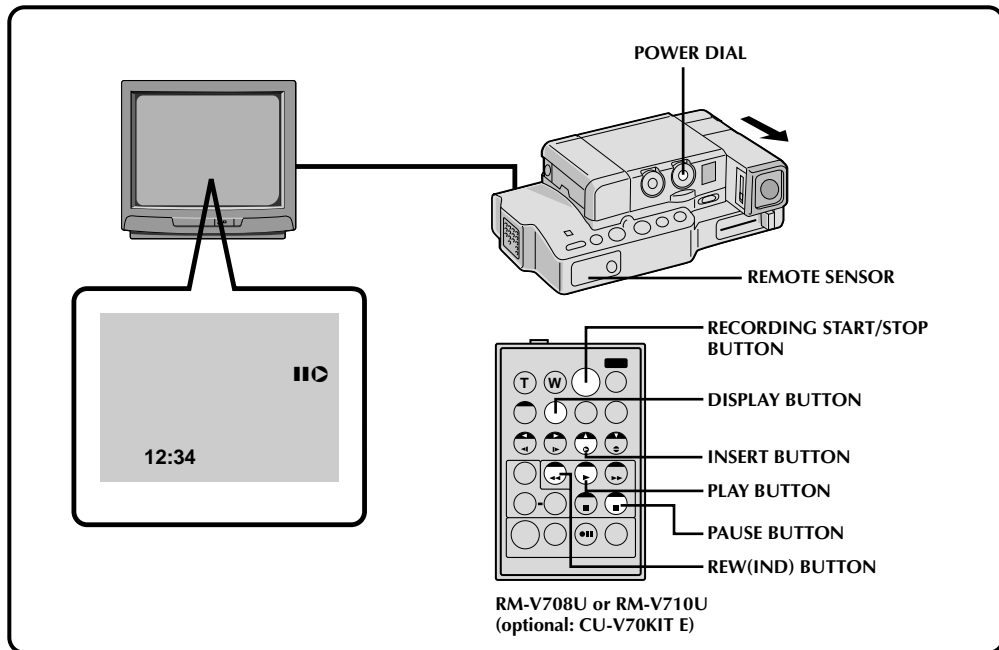

1 FIND EDIT OUT POINT

Confirm the time code at this point.
(☞ pg. 47)

2 FIND EDIT IN POINT

Press **REW** until the point is located, then press **PAUSE**.

3 PREPARE FOR INSERT EDITING

Press and hold **INSERT** on the remote control, then press **PAUSE**. "IIC" and the Time Code (min.:sec.) appear in the viewfinder.

NOTE:

To see the on-screen characters on a connected TV, press **DISPLAY** on the remote control.
(☞ pg. 50)

4 START RECORDING

Press **RECORDING START/STOP** to begin editing.

- Confirm the insert at the time code you checked in step 1.

5 PAUSE DURING EDITING

Press **RECORDING START/STOP**. Press again to resume editing.

6 STOP EDITING

Press **RECORDING START/STOP**, then press **STOP**.



NOTES:

- When performing Insert Editing, the tape's Video Area and Sub-Code Area (☞ pg. 5) are rewritten, so the date and time information changes.
- If you perform Insert Editing onto a blank space on the tape, the audio and video may be disrupted. Make sure you only edit recorded areas.

If, after following the steps in the chart below, the problem still exists, please consult your nearest JVC dealer or Technical Service Center.

SYMPTOM	POSSIBLE CAUSES	CORRECTIVE ACTION
1. No power is supplied.	1. • The power is not connected properly. • The battery is dead. • The viewfinder hasn't been pulled out.	1. • Connect the AC Adapter securely (☞ pg. 10). • Replace the dead battery with a fully charged one (☞ pg. 9). • Pull the viewfinder out.
2. Recording cannot be performed.	2. • The tape's record safety tab is set to "SAVE". • The Power Dial is set to "PLAY".	2. • Set the tape's record safety tab to "REC" (☞ pg. 13). • Set the Power Dial to "REC".
3. There is no playback picture.	3. • The camcorder is not getting power, or some other malfunction exists. • The lens cover is closed.	3. • Turn the camcorder's power off and on again. • Pull out the viewfinder to open the lens cover.
4. Some functions are not available.	4. • The Select Dial is set to "AUTO". • The Power Dial is set to "5S".	4. • Set the Select Dial to any position except "AUTO". • Set the Power Dial to any position except "5S".
5. The focus does not adjust automatically.	5. • Focus is set to "MANUAL". • The recording was done in a dark place, or the contrast was low. • The diopter is not properly adjusted. • The lens is dirty or covered with condensation.	5. • Set Focus to "AUTO" (☞ pg. 37). • Adjust the diopter (☞ pg. 14). • Clean the lens and check the focus again.
6. The cassette won't load properly.	6. • The cassette is in the wrong position. • The battery's charge is low.	6. • Set it in the right position. • Install a fully charged battery.
7. Play, Rewind and Fast-Forward functions don't work.	7. • The Power Dial is not set to "PLAY". • The cassette's cover is open.	7. • Set the Power Dial to "PLAY" (☞ pg. 45).
8. The tape is moving, but there's no picture.	8. • Your TV has AV input terminals, but is not set to its VIDEO mode.	8. • Set the TV to the mode or channel appropriate for video playback.
9. When shooting a subject illuminated by bright light, vertical lines appear.	9. • This is a result of exceedingly high contrast, and is not a malfunction.	9. _____
10. In the 5-Second mode, recording ends before 5 seconds have elapsed.	10. • The 5-Second mode in the System Menu is set to "ANIMATION".	10. • Select "5S" or "5SD" in the System Menu (☞ pgs. 19, 20).
11. Even though "GAIN UP" was set to "A 2 5", scenes shot in dark places are not brightened.	11. • Depending on the light source, the 1/30 shutter speed may be deactivated in order to reduce the shakiness in the picture.	11. _____
12. Snapshot mode cannot be used.	12. • P.AE/Effects Sepia, Monotone or Slow (Slow Shutter) are activated. • The Squeeze mode is selected. • The Cinema mode is engaged, disabling the white border.	12. • Disengage them. • Disengage the Squeeze mode. • Disengage the Cinema mode.

SYMPTOM	POSSIBLE CAUSES	CORRECTIVE ACTION
13. Digital Zoom doesn't work.	13. • 10x optical zoom is selected. • The Video Echo effect is activated. • Picture Wipe or Dissolve are being used in a scene transition. • 5-Second recording was done with the Power Dial set to "5S", and with "5SD" selected in the System Menu. • Snapshot Dissolve was attempted during Digital Zoom.	13. • Turn off the Video Echo effect. • Wait until the Picture Wipe or Dissolve effects are completed. • Change the setting of either the System Menu or the Power Dial. • Do not attempt to take a Snapshot when performing Digital Zoom.
14. P.AE/Effects and Fade/Wipe Effects don't work.	14. • The Select Dial is set to "AUTO". • The Power Dial is set to "5S".	14. • Set the Select Dial to "MANUAL". • Change the setting of the Power Dial.
15. The Black & White Fader doesn't work.	15. • The Sepia or Monotone effects are activated.	15. • Turn off Sepia and Monotone.
16. The Dissolve function doesn't work.	16. • P.AE/Effects Sepia, Monotone or Slow are activated. • The Squeeze mode is selected.	16. • Turn off Sepia and Monotone before adding Dissolve to a scene transition. • Make sure that the Squeeze mode in the Recording Menu is set to "OFF".
17. The Picture Wipe and Dissolve functions don't work.	17. • The last selected editing scene is ending. • At the end of the last selected scene for editing, the Power Dial was set to "OFF". • The power is off. • The previously selected P.AE/Effect was changed after the last selected scene for editing was registered. • The P.AE/Effects in the Recording Menu were exchanged after the last selected scene for editing was registered.	17. • Select Picture Wipe or Dissolve before beginning recording. The effects are then automatically activated. • Do not turn off the camcorder's power after setting Edit-In and Edit-Out points, as they will all be erased. • The camcorder automatically shuts off after 5 minutes have elapsed in the RECORD/STANDBY mode. Make sure you continue operations within 5 minutes after engaging RECORD/STANDBY. • Make sure you have selected the P.AE/Effects you want before starting editing. • Exchanging P.AE/Effects may deactivate the effect(s) you selected. Once you've selected an effect, do not perform an exchange before beginning editing. If you do, make sure you don't replace the effect(s) you selected.

SYMPTOM	POSSIBLE CAUSES	CORRECTIVE ACTION
18. The Picture Wipe function doesn't work.	18. • The Slow (Slow Shutter) effect is activated. • The Squeeze or Cinema mode is selected in the Recording Menu.	18. • Make sure the Squeeze mode, Cinema mode, or Slow effect is not activated when preparing to use the Picture Wipe function.
19. Even when Slow (Slow Shutter) isn't selected, the image looks like it is activated.	19. • When shooting in the dark with GAIN UP set to A  , the unit becomes highly sensitive to light and the image takes on an effect similar to Slow (Slow Shutter).	19. • If you want the lighting to look more natural, set GAIN UP to "AGC" or "OFF" in the Recording Menu.
20. The Video Echo effect doesn't work.	20. • The Picture Wipe or Dissolve functions are in use. • The Squeeze mode is selected in the Recording Menu. • Snapshot Dissolve is in progress. • A Fade-In or Fade-Out is in progress (White Fader, Black Fader or Black & White Fader).	20. • Make sure the Squeeze mode is set to "OFF". • Do not try to use the Video Echo effect during a Fade-In or Fade-Out.
21. There is no strobe when the Classic Film and Strobe effects are activated.	21. • The Picture Wipe or Dissolve functions are in use. • Snapshot Dissolve is in progress.	21. • Do not try to use the Classic Film or Strobe effects during a scene transition.
22. White Balance cannot be activated.	22. • The Sepia or Monotone effects are activated. • Snapshot Dissolve is in progress.	22. • Turn off Sepia or Monotone before setting White Balance. • Wait until the Snapshot Dissolve is finished before setting White Balance.
23. The viewfinder indications blink.	23. • Certain FADE/WIPE, P.AE/Effects and other functions that cannot be used together are selected at the same time.	23. • Re-read the sections covering FADE/WIPE and P.AE/Effects ( pg. 29, 34).
24. There are disturbances in audio and video.	24. • If Audio Dubbing or Insert Editing have been performed repeatedly on the same portion of the tape, disturbance to the sound and picture may result.	24. • Use a new, or infrequently used, tape for Audio Dubbing and Insert Editing.
25. An unusual mark appears in the viewfinder.	25. _____	25. • Check the section of the manual that explains viewfinder indications ( pg. 64).
26. An error indication (E01 — E07) appears in the viewfinder.	26. • A malfunction of some kind has occurred. In this case the camcorder's functions become unusable.	26. • Remove the tape or the battery pack, and wait a few minutes for the indication to clear. When it does, you can resume using the camcorder. If the indication remains, please consult your nearest JVC dealer or Technical Service Center.

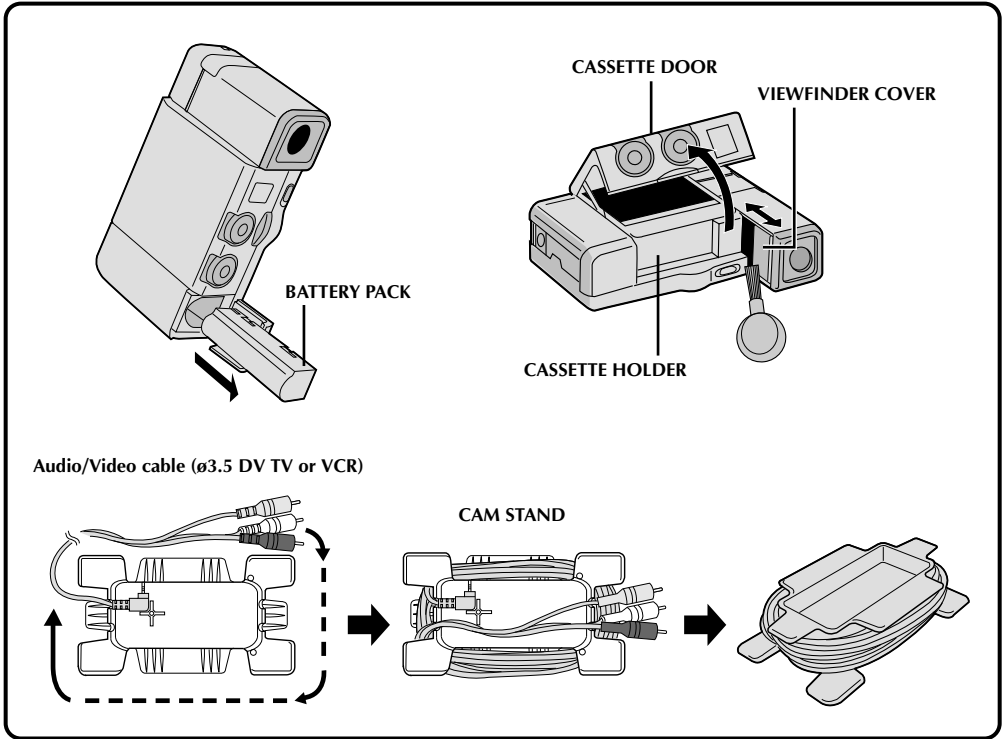

Cleaning The Camcorder

- 1 CLEAN EXTERIOR**
Wipe gently with a soft cloth.
- 2 CLEAN LENS**
Blow it with a blower brush, then wipe gently with lens cleaning paper.
- 3 REMOVE POWER SUPPLY**
Remove the battery pack or disconnect the AC Power Adapter/Charger.
- 4 OPEN CASSETTE DOOR**
There is no power to the camcorder, so the cassette holder won't open.
- 5 PULL OUT VIEWFINDER**
Pull out the viewfinder and slide its cover open.
- 6 CLEAN VIEWFINDER**
Remove dust using a blower brush.

- 7 RESET VIEWFINDER**
Close the viewfinder's cover and push the viewfinder back in.

- 8 CLOSE CASSETTE DOOR**

Audio/Video Cable And CAM Stand

- 1 WRAP CABLE AROUND STAND**
Position the plug of the Audio/Video cable (ø3.5 DV TV or VCR) as shown in the illustration, then wrap the cable around the stand in the direction indicated.
- 2 CONFIRM PLUG POSITION**
Make sure the white, red and yellow plugs are positioned as shown in the illustration.

Main Unit

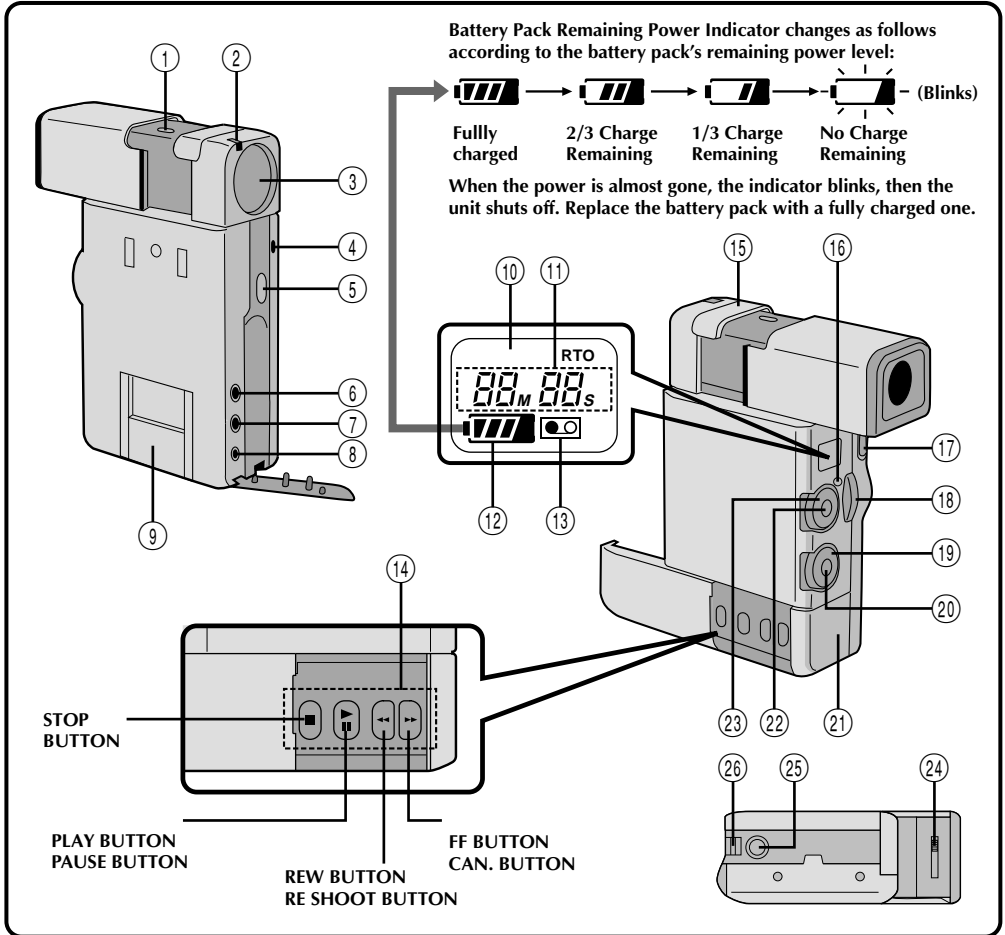

- ① **MENU Button** (☞ pg. 17)
- ② **White Balance Sensor**
* Take care not to cover the sensor with your hand while shooting.
- ③ **Lens** (☞ pg. 10)
- ④ **Tally Lamp**
The tally lamp lights while recording is in progress.
- ⑤ **SNAPSHOT Button** (☞ pg. 23)
- ⑥ **Ext. Mic Input Jack** (☞ pg. 57)
- ⑦ **AV Output Jack** (☞ pg. 10)
- ⑧ **DC Input Jack** (☞ pg. 10)
- ⑨ **Multi Connector**
* Located inside the cover. Connect to the Docking Station's multi connector. To avoid malfunction, do not touch this connector or force the cover open.
- ⑩ **LCD Display Window**
- ⑪ **Remaining Tape Time (during recording)**
Time Code (during playback)
- ⑫ **Remaining Battery Power Indicator** (☞ pg. 63)
- ⑬ **"No Tape Loaded" Indicator**
- ⑭ **Tape Advance Buttons** (☞ pg. 22, 45)
- ⑮ **Stereo Microphone**
- ⑯ **Power Lamp** (☞ pg. 21)
- ⑰ **OPEN/EJECT Switch** (☞ pg. 13)
- ⑱ **Zoom Lever** (☞ pg. 12)
- ⑲ **Select Dial** (☞ pg. 16)
- ⑳ **SET Button** (☞ pg. 17)
- ㉑ **Battery Cover** (☞ pg. 9)
- ㉒ **RECORDING START/STOP Button** (☞ pg. 21)
- ㉓ **Power Dial** (☞ pg. 12)
- ㉔ **Diopter Adjust Lever** (☞ pg. 14)
- ㉕ **Tripod Mounting Socket**
- ㉖ **Hand Strap Eyelet** (☞ pg. 14)

Viewfinder Indications

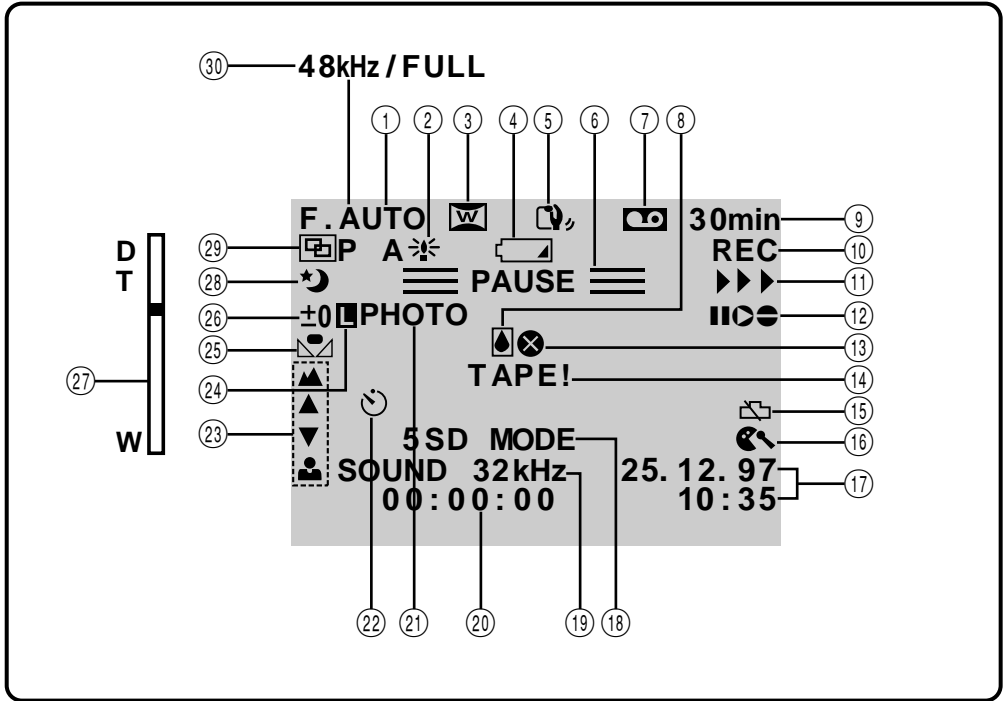

Recording And Playback

No.	NAME & FUNCTION
①	Select Dial Position (☞ pg. 16)
②	GAIN UP Indicator (☞ pg. 18)
③	Wide Mode (☞ pg. 18)
④	“Battery Low” Indicator Appears and blinks when battery charge is low.
⑤	Digital Image Stabilizer Indicator (☞ pg. 18)
⑥	Record-Standby Indicator (☞ pg. 25)
⑦	“Cassette Loaded” Indicator Appears when no tape is loaded, or when you try to record with the record safety tab set to “SAVE”.
⑧	Condensation Warning When this indicator appears, all functions are disabled. Turn the unit off for a few hours, and when you turn it on again the indicator should disappear.

No.	NAME & FUNCTION
⑨	Tape Remaining Indicator (☞ pg. 22)
⑩	Recording Indicator (☞ pg. 20)
⑪	“Tape Running” Indicator (☞ pg. 21)
⑫	Audio Dubbing/Insert Editing Mode Indicator (☞ pgs. 57, 58)
⑬	Head clog warning At the start of recording, appears and blinks if dirt is detected on heads. Stop recording and clean the heads using the Cleaning Cassette. (☞ pg. 67)
⑭	“No Tape Loaded” Indicator Appears for 15 seconds after power is turned on if there's no tape loaded.
⑮	Clock Battery Warning Appears when the clock (lithium) battery is not in place or exhausted. For inserting or replacing the clock battery, refer to page 10.
⑯	Wind Cut Indicator (☞ pg. 20)
⑰	Date/Time Display (☞ pg. 12)
⑱	Recording Mode Indicator (☞ pg. 25)
⑲	Sound Mode Display (☞ pg. 20)
⑳	Time Code Display (☞ pg. 27)
㉑	Snapshot Indicator (☞ pg. 23)
㉒	Self-Timer Indicator (☞ pg. 26)
㉓	Focus Indicators (☞ pg. 37)
㉔	Iris Lock Indicator (☞ pg. 39)
㉕	White Balance Indicator (☞ pg. 40)
㉖	Exposure Indicator (☞ pg. 38)
㉗	Zoom Level Indicator (☞ pg. 24)
㉘	P.AE/Effect Indicator (☞ pg. 34)
㉙	FADE/WIPE Indicator (☞ pg. 29)
⑳	Playback Sound Mode Display (☞ pg. 46)
—	“Tape End” Indicator (☞ pg. 22)
—	An error number (E01, etc.) appears in the viewfinder. Consult your nearest JVC dealer. (☞ pg. 67)

Battery Packs

The supplied battery pack is a lithium-ion battery. Before using the supplied battery pack or an optional battery pack, be sure to read the following cautions:

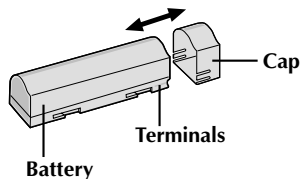

1. To avoid hazard . . .

- do not burn.
- do not short-circuit the terminals.
- do not modify or disassemble.
- use only specified chargers.

2. To prevent damage and prolong service life . . .

- do not subject to unnecessary shock.
- charge in an environment where temperatures are within the tolerances shown in the chart below. This is a chemical reaction type battery—cooler temperatures impede chemical reaction, while warmer temperatures can prevent complete charging.
- store in a cool, dry place. Extended exposure to high temperatures will increase natural discharge and shorten service life.
- avoid prolonged uncharged storage.
- remove from charger or powered unit when not in use, as some machines use current even when switched off.

3. To prevent damage to the camcorder . . .

- replace the battery pack when it begins to deliver less recording time per charge.

NOTE:

It is normal for the battery pack to be warm after charging, or after use.

Temperature Range Specifications

Charging	10°C to 35°C
Operation	10°C to 40°C
Storage	-10°C to 30°C

NOTES:

- Recharging time is based on room temperature of 20°C.
- The lower the temperature, the longer recharging takes.

Cassettes

To properly use and store your cassettes, be sure to read the following cautions:

1. During use . . .

- make sure the cassette bears the Mini DV mark.
- be aware that recording onto prerecorded tapes automatically erases the previously recorded video and audio signals.
- make sure the cassette is positioned properly when inserting.
- do not load and unload the cassette repeatedly without allowing the tape to run at all. This slackens the tape and can result in damage.
- do not open the front tape cover. This exposes the tape to fingerprints and dust.

2. Store cassettes . . .

- away from heaters or other heat sources.
- out of direct sunlight, where they won't be subject to unnecessary shock or vibration.
- where they won't be exposed to strong magnetic fields (such as those generated by motors, transformers or magnets).
- vertically, in their original cases.

Main Unit

1. For safety, DO NOT . . .

- open the camcorder's chassis.
- disassemble or modify the unit.
- short-circuit the terminals of the battery pack. Keep it away from metallic objects when not in use.
- allow inflammables, water or metallic objects to enter the unit.
- remove the battery pack or disconnect the power supply while the power is on.
- leave the battery pack attached when the camcorder is not in use.

2. Avoid using the unit . . .

- in places subject to excessive humidity or dust.
- in places subject to soot or steam such as near a cooking stove.
- in places subject to excessive shock or vibration.
- near a television set.
- near appliances generating strong magnetic or electric fields (speakers, broadcasting antennas, etc.).
- in places subject to extremely high (over 40°C) or extremely low (under 0°C) temperatures.

3. DO NOT leave the unit . . .

- in places of over 50°C.
- in places where humidity is extremely low (below 35%) or extremely high (above 80%).
- in direct sunlight.
- in a closed car in summer.
- near a heater.

4. To protect the unit, DO NOT . . .

- allow it to become wet.
- drop the unit or strike it against hard objects.
- subject it to shock or excessive vibration during transportation.
- keep the lens directed at extremely bright objects for long periods.
- direct the eyepiece of the viewfinder at the sun.
- carry it by holding the viewfinder.
- swing it excessively when using the shoulder strap.

5. Dirty heads can cause the following problems:

- No picture during playback.
- Blocks of noise appear during playback.
- During recording, the Head Clog Warning indicator "⊗" appears in the viewfinder.



In such cases, use the optional Cleaning Cassette M-DV2CL. Insert it and play back for approximately 20 seconds. After this time the camcorder stops automatically. If the cassette is used more than once consecutively, damage to the video heads may result.

If, after using the Cleaning Cassette, the problems still exist, consult your nearest JVC dealer.

About moisture condensation . . .

- You have observed that pouring a cold liquid into a glass will cause drops of water to form on the glass' outer surface. This same phenomenon occurs on the head drum of a camcorder when it is moved from a cool place to a warm place, after heating a cold room, under extremely humid conditions or in a place directly subjected to the cool air from an air conditioner.
- Moisture on the head drum can cause severe damage to the video tape, and can lead to internal damage to the camcorder itself.

Serious malfunctioning

If malfunctioning occurs, stop using the unit immediately and consult your local JVC dealer.

The camcorder is a microcomputer-controlled device. External noise and interference (from a TV, a radio, etc.) might prevent it from functioning properly. In such cases, first disconnect its power supply unit (battery pack, AC Power Adapter/Battery Charger, etc.) and clock battery; and then re-connect it and proceed as usual from the beginning.

MAIN UNIT**General**

Power	: DC 6 V $\overline{\text{---}}$ (using AC Adapter), DC 3.6 V $\overline{\text{---}}$ (using Battery)
Power consumption	: 6.2 W
Format	: DV Format (SD mode)
Signal format	: PAL Standard
Video signal recording format	: Digital Component Recording
Data compression rate	: 25 Mbps
Digital compression technology	: DCT (Discrete Cosine Transform) & VLC (Variable Length Coding)
Cassette	: MINI DV Cassette
Tape Speed	: 18.8 mm/sec.
Maximum recording time	: 60 min. (using DVM-60 cassette)
Continuous recording time	: Approx. 50 min. (using fully charged BN-V714U Battery Pack)
Fast-Forward/Rewind Time	: Approx. 90 sec. (using DVM-60 cassette)
Pickup	: 1/3" CCD
Zoom	: 10x Optical Zoom 20x/100x Digital Zoom
Lens diameter (Filter Diameter)	: F1.6, f = 4.5~45 mm $\varnothing 27$
Viewfinder	: Electronic 0.55" color LCD
White balance	: AUTO/MAN.
Iris	: AUTO/LOCK
Microphone	: Condensor type/stereo
Operating temperature	: 0 — 40°C
Operating humidity	: 35 — 80%
Storage temperature	: -20 — 50°C
Dimensions	: 43 (W) x 148 (H) x 88 (D) mm
Weight	: Main unit approx. 450 g
During recording	: Approx. 520 g (With BN-V714U Battery Pack, Cassette M-DVM30ME, Hand Strap)

Audio

Sampling frequencies	: 48 kHz, 44.1 kHz (playback), 32 kHz
Channels	: 2 (48 kHz) 4 (32 kHz)
Quantum Bits	: 16 linear (48 kHz) 12 non-linear (32 kHz)

Connectors

Microphone input connector	: $\varnothing 3.5$ mm -62 dB stereo
A/V output connector	: $\varnothing 3.5$ mm 4 quadripolar (analog output)
DC input connector	: 6 V
Multi connector	: 34 pin

Battery Pack BN-V714U

Power	: DC 3.6 V --- /1350mAh
Dimensions	: 20 mm (W) x 20 mm (H) x 71 mm (D)
Weight	: Approx. 50 g

AC Adapter/Charger AA-V70EK

Power	: AC 110–240 V \sim , 50/60 Hz
Power consumption	: 15 W
Output power	: DC 3,6 V --- , 1,3 A (charge) : DC 6,0 V --- , 1,1 A (VTR)
Operating temperature	: 0°C — 40°C (when charging, 10°C — 35°C)
Dimensions	: 112 mm (W) x 44 mm (H) x 63 mm (D)
Weight	: Approx. 185 g

Iris

Works like the pupil of the human eye. In a well-lighted environment, the human pupil contracts to keep too much light from entering. In low lighting, the pupil dilates to allow more light in.

Colour temperature

A measurement in Kelvin degrees which indicates the colour contents of a light source; bluish light has a higher colour temperature than reddish light. To reproduce white as white under different types of lighting, the chrominance signal must be adjusted to match the light source's colour temperature.

(See "White Balance".)

AC Adapter

Used when charging the battery. Or, when connected directly to the camcorder, it can be used as a power supply.

Auto focus

Focus can be set for automatic adjustment, for beginners who find the adjustment difficult.

On-screen display

Displays in the viewfinder can be shown on a connected TV.

Strobe

In the early days of movie making, 1-second strobes were uncommon, so movies didn't have the smooth movement they have today. This function gives movies the old-film flicker effect.

Record/Standby

Engage this mode by pressing START/STOP during Stop or Record modes. It means that the GR-DV1, or your VCR, is paused and ready to record.

CCD (Charge coupled device)

Solid-state imaging device used in camcorders as the camera's image pickup; analogous to the eye's retina except that picture information is output as electric signals.

Diopter adjustment

Reacts to your eye strength, making viewfinder indications and images easier to see.

Dew sensor

If condensation forms inside the unit due to a temperature change, the indicator appears in the viewfinder, and the camcorder becomes unusable.

Digital zoom

10x Optical zoom image is taken and digitally processed to provide 20x or 100x magnified images.

Digital Image Stabilizer

When shooting while holding the camcorder in your hand, even if you think you're perfectly still, there is slight movement. This function compensates for that movement.

Fade

An effect used in scene transitions. Like movies or TV, the scene gradually goes black or white (fade out), or comes in from a black or white screen (fade in).



White balance

A term that refers to the correctness of colour reproduction under various lighting. If the white balance is correct, all other colours will be accurately reproduced.



Wipe

An effect used in scene transitions. A scene disappears as though it's being wiped off the screen (wipe out), or appears as though it's wiped on (wipe in).

A

- Animation  pg. 20
- Audio Dubbing  pg. 57
- Auto Focus  pg. 37



B

- Battery  pg. 8
- Battery Low  pg. 63



C

- Charging  pg. 8
- Charging While Docked  pg. 42
- Cleaning The Camcorder  pg. 62
- Connections  pg. 42





D

- Date/Time Display  pg. 28
- Date/Time Settings  pg. 12
- Digital Zoom  pg. 18
- Diopter Adjustment  pg. 14
- Docking Station  pg. 42
- Dubbing  pg. 50



E

- Editing  pg. 50
- Erase protection  pg. 13
- Exposure Control  pg. 38



F

- 5SD  pg. 25
- 5-Second Mode  pg. 25
- Fade-In/Out  pg. 30
- Focus Adjustment  pg. 37

G**H****I**

- Insert Editing  pg. 58
- Iris  pg. 39
- Iris Lock  pg. 39



J**K****L**

- Lithium Battery  pg. 2
- Loading A Tape  pg. 13





M**N****O**

- On-Screen Menus  pg. 17









P

- P.AE/Effects  pg. 34
- Playback On TV  pg. 43
- Power (AC/Battery)  pgs. 8, 10



Q**R**

- Random Assemble Editing  pg. 52
- Record/Standby  pg. 6
- Recording Format  pg. 6
- Remote Control  pg. 15

S

- Self-Timer  pg. 26
- Set VCR Brand  pg. 51
- Shooting Posture  pg. 22
- Slow Motion Playback  pg. 48
- Snapshot Mode  pg. 23
- Snapshot Search  pg. 23
- Sound  pg. 20
- Stabilizer  pg. 18
- Strobe  pg. 35



T

- Tapes  pg. 13
- Time Code  pg. 5

U**V**

- Viewfinder Indications  pg. 64

W

- White Balance  pg. 40
- Wide  pg. 18
- Wipe In/Out  pg. 30

